

# **Bäumr-AG**

## **50 Ton Diesel Log Splitter**

### **User Manual**

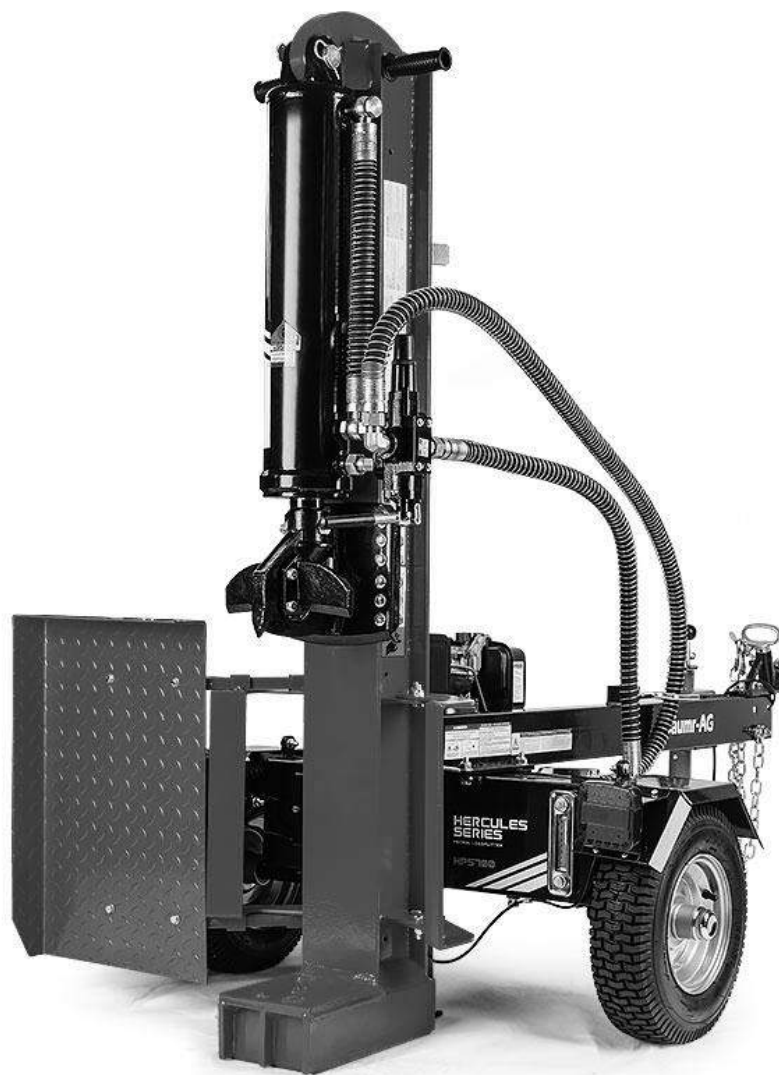

**RETAIN THIS MANUAL FOR FUTURE REFERENCE**

**PLEASE READ THIS MANUAL CAREFULLY BEFORE USE**

# Table of Contents

<b>GENERAL WARNING</b> .....	<b>1</b>
Operation Warnings.....	1
Crush and Cut Hazards.....	1
Assembly is Required.....	1
<b>HAZARD SIGNAL WORD DEFINITIONS</b> .....	<b>2</b>
<b>ABOUT YOUR 50 TON LOG SPLITTER</b> .....	<b>3</b>
<b>COMPONENTS PARTS</b> .....	<b>4</b>
Parts Found in your Log Splitter Box.....	4
Hardware Box.....	5
<b>CONTROLS AND FEATURES IDENTIFICATION</b> .....	<b>6</b>
<b>50 TON LOG SPLITTER ASSEMBLY</b> .....	<b>7</b>
Assembly Instructions.....	7
Step 1: Attach Tow Bar.....	7
Step 2: Attach the Wheel.....	8
Step 3: Attach the Rear Support Leg.....	8
Step 4: Attach the Led.....	9
Step 5: Attach the Fender.....	9
Step 6: Attach the Engine Mounting Plate.....	10
Step 7: Attach the Beam.....	10
Step 8: Attach the Gear Pump.....	11
Step 9: Attach the Engine and Oil Pipe.....	11
Step 10: Attach the Wood Table and Log Cradle.....	12
Step 11: Attach the License Lamp.....	12
Step 12: Wiring.....	13
Step 13: Attach the Cross Wedge.....	13
Step 14: Add the Engine Oil.....	14
Step 15: Add Diesel Fuel to the Engine.....	14
Step 16: Add the Hydraulic Oil.....	15
<b>OPERATION INSTRUCTIONS</b> .....	<b>16</b>
Using Your Log Splitter.....	16
<b>MAINTENANCE AND STORAGE</b> .....	<b>19</b>
Maintenance.....	19
Storage.....	20
<b>TROUBLESHOOTING</b> .....	<b>21</b>
<b>SPECIFICATIONS</b> .....	<b>22</b>
Size and Weight.....	22
<b>PARTS DRAWING AND PARTS LIST</b> .....	<b>23</b>

# General Warning

## READ and UNDERSTAND this manual completely before using 50 Ton Log Splitter.

Operator must read and understand all safety and warning information, operating instructions, maintenance and storage instructions before operating this equipment. Failure to properly operate and maintain the log splitter could result in serious injury to the operator or bystanders.

## Operation Warnings

- Do not at any time carry passengers, sit or stand on the log splitter.
- Do not allow children to play on, stand upon or climb on the log splitter.
- Always inspect the log splitter before using it to assure it is in good working condition.
- Replace or repair damaged or worn parts immediately.
- Always check and tighten hardware and assembled parts before operation.
- Do not exceed equipment maximum load capacity of 50 tons.
- Avoid large holes and ditches when towing the equipment.
- Always operate the log splitter on clear and level ground.
- Do not operate the log splitter at night, only during daylight hours.
- Always tow at reduce speed in rough terrain, along creeks, ditches and on hillsides.
- To avoid personal injury and/or equipment damage, **DO NOT EXCEED 45 MPH.**
- Always refer to the vehicle owner's manual for proper towing.
- Always secure and lock the log splitter to the vehicle hitch before towing.

## Crush and Cut Hazards

- Always keep hands and feet clear from moving parts while operating the equipment.
- Always keep work area clean and free of debris when operating.
- Always wear safety gear, eye protection, gloves and work boots when operating the log splitter.







### **WARNING**

The warnings, cautions, and instructions outlined in this instruction manual cannot cover all possible conditions or situations that may occur. It must be understood by the operator that common sense and caution are factors which cannot be built into this product and must be supplied by the operator.

## Assembly is Required

This product requires assembly before use. See "Assembly" section for instructions. Because of the weight and/or size of the log splitter, it is recommended that another adult be present to assist with the assembly. **INSPECT ALL COMPONENTS** closely upon receipt to make sure no components are missing or damaged.

## Hazard Signal Word Definitions

	<p>This is the safety alert symbol. It is used to alert you to potential personal injury hazards. Obey all safety messages that follow this symbol to avoid possible injury or death.</p>
	<p><b>DANGER</b> indicates an imminently hazardous situation which, if not avoided, will result in death or serious injury.</p>
	<p><b>WARNING</b> indicates a potentially hazardous situation which, if not avoided, could result in death or serious injury.</p>
	<p><b>CAUTION</b> indicates a potentially hazardous situation which, if not avoided, may result in minor or moderate injury.</p>
	<p><b>CAUTION</b> used without the safety alert symbol indicates a potentially hazardous situation which, if not avoided, may result in property damage.</p>

## About Your 50 Ton Log Splitter

This hydraulic log splitter has a heavy-duty steel construction and 50 tons of ram force. When there's work to be done, you need outdoor power equipment that you can rely on. This log splitter will get the job done fast. It is designed to work in both horizontal and vertical position. It is easy to tow, easy to use and easy to maintain. Never exceed the rated capacity of 50 tons when operating the log splitter.























Technical specifications on the log splitter are provided in the "Specifications" section of this manual.

# Components Parts

## Parts Found in your Log Splitter Box





**Hardware Box**

- |   |   |  |   |  |   |
|---|---|--|---|--|---|
| #41<br>Hex Bolt M10x30<br>18 pcs<br>   | #39<br>Hex Bolt M8x35<br>4 pcs<br>   | #54<br>Hex Bolt M12x40<br>4 pcs<br>     | #45<br>Hex Bolt M10x75<br>5 pcs<br> | #85<br>Big Flat Washer<br>4 pcs<br> | #47<br>R Pin<br>1 pc<br>             |
| #55<br>Nylon Lock Nut M12<br>4 pcs<br> | #5<br>Nylon Lock Nut M8<br>4 pcs<br> | #43<br>Nylon Lock Nut M10<br>23 pcs<br> | #33<br>Flat Washer Ø12<br>4 pcs<br>  | #4<br>Flat Washer Ø8<br>4 pcs<br>   | #42<br>Flat Washer Ø10<br>23 pcs<br> |
| #46<br>Hitch Pin<br>1 pc<br>           | #105<br>Rubber Washer<br>6 pcs<br>   | #84<br>Polyurethane Block<br>4 pcs<br>  | #100<br>ORing Ø13x2.5<br>1 pc<br>    | #25<br>ORing Ø17x2.5<br>1 pc<br>    | Ø6 Big Flat Washer<br>2 pcs<br>      |
| Hex Bolt M6x16<br>2 pcs<br>          | Lock Washer Ø6<br>2 pcs<br>        | WCL-6 Wire Seat<br>3 pcs<br>          | Cable 3*200<br>3 pcs<br>         |  |   |

# Controls and Features Identification

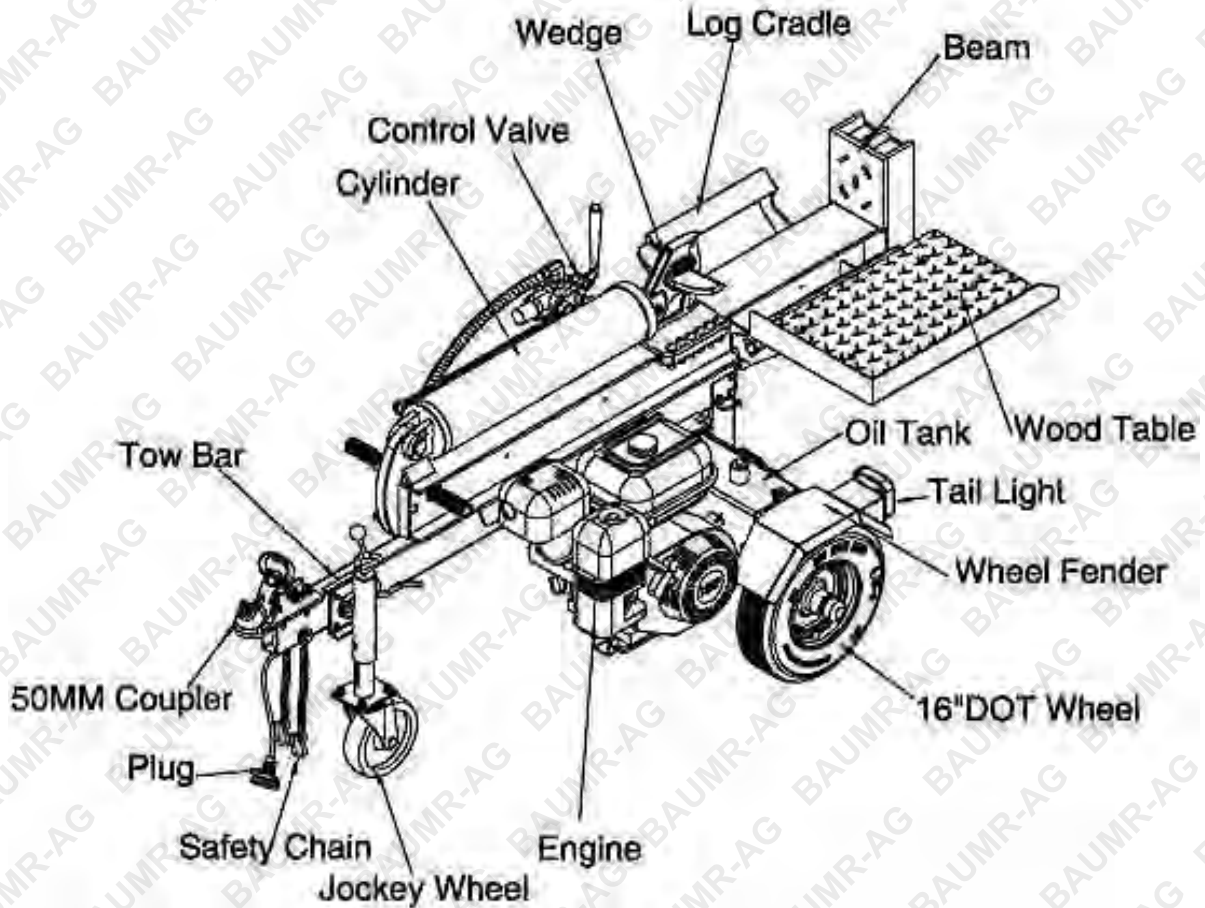
Read this owner's manual before operating the equipment. Familiarize yourself with the location and function of the controls and features. Save this manual for future reference.



	<p><b>Engine Shipped Without Oil</b> Before starting the engine, fill it with SAE 10W-30 motor oil. See engine manual for engine oil capacity.</p> <p><b>Hydraulic Oil Tank is Shipped Without Oil</b> When adding oil, verify the oil level using the Oil filter/Dip Stick on the top of the hydraulic oil tank. If the marking is not shown, fill it up to the L line.</p> <p><b>Inspect all Log Splitter Components</b> If you have damaged components, contact the freight company that delivered the log splitter and file a claim.</p>
---	--



**CAUTION**

Read and follow all instructions for assembly and operation. Failure to properly assemble this equipment could result in serious injury to the user or bystanders, or cause equipment damage.



# 50 Ton Log Splitter Assembly

Set the shipping crate on a solid flat surface and carefully remove the lid. Use two people and take all parts out of the shipping crate. Inspect the components to ensure that there are no missing pieces. Before starting to assemble the log splitter, follow steps 1 through 7.

## Tools Required

- Rubber or Wooden Hammer
- 13mm, 16mm, 17mm, 18mm, 19mm, 24mm, 27mm Wrenches
- Large Adjustable Wrench
- Phillips Screwdriver
- Pliers

## Assembly Instructions

### Step 1: Attach Tow Bar

1. Attach the tow bar to the oil tank (#51) using hex bolt M12x40 (#54), flat washer Ø12 (#33) and nylon lock nut M12 (#55).
2. Connect the oil pipe (#104) to the oil tank (#51) using the clamp (#103).

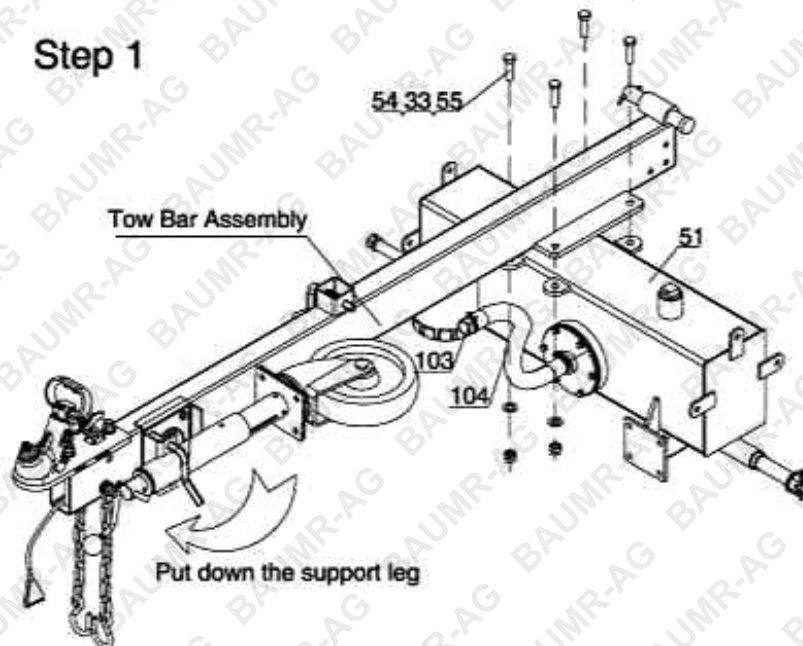

**Step 2: Attach the Wheel**

1. Take off the flat washer Ø20 (#58), hex slotted nut (#74) and cotter pin Ø3X30 (#7) from the axle.
2. Attach the wheels (#77) to the oil tank using flat washer Ø20 (#58), hex slotted nut (#74) and cotter pin Ø3X30 (#7). Install the axle cap (#75) on the end.

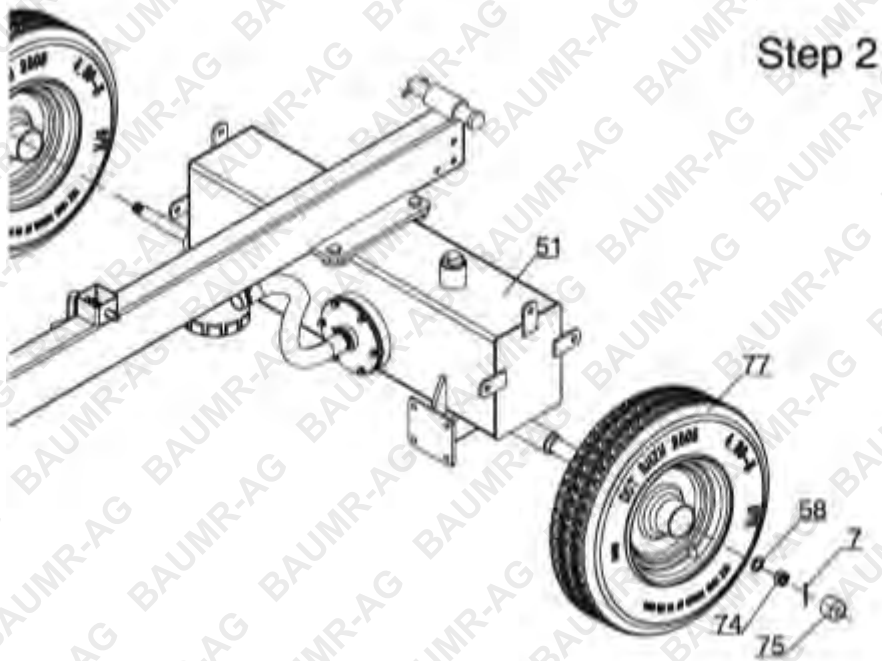

**Step 3: Attach the Rear Support Leg**

1. Attach the rear support leg (#44) to the tow bar assembly using hex bolt M10x75 (#45), flat washer Ø10 (#42) and lock nut M10 (#43), insert the handle ring and R Pin (#47).

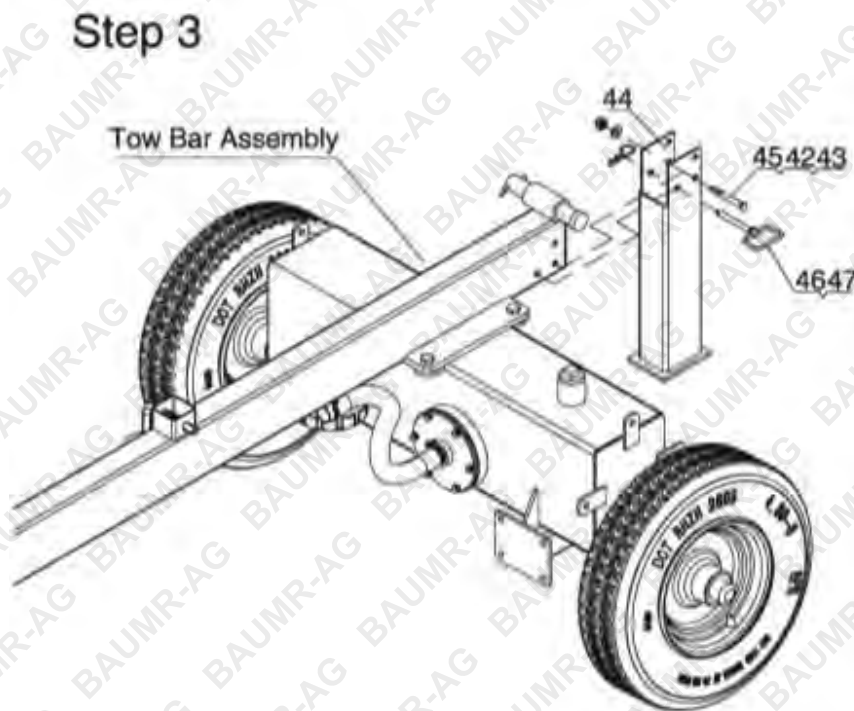

**Step 4: Attach the Led**

1. Unscrewing the nut on the led, through the plug into the hole of tail light mounting plate, adjust the direction of the led, install the bolt into the light socket, screw the two nut.

**NOTE:** the line on the right side is longer than left side.

**Step 4**

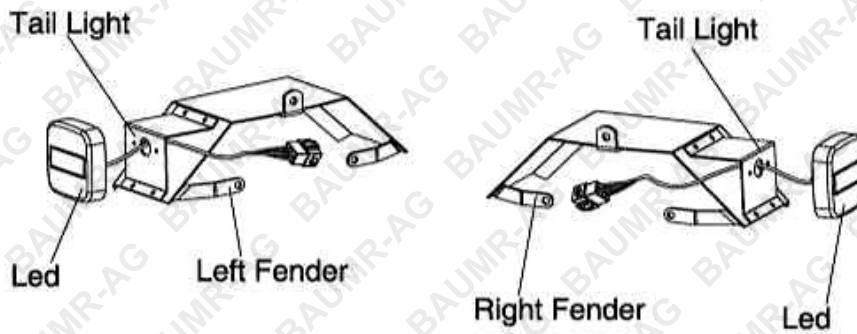

**Step 5: Attach the Fender**

1. Attach the left & right fenders (#53, #56) to the oil tank using hex bolt M10x30 (#41), flat washer Ø10 (#42) and lock nut M10 (#43). Put a rubber washer (#105) between fender and oil tank.

**Step 5**

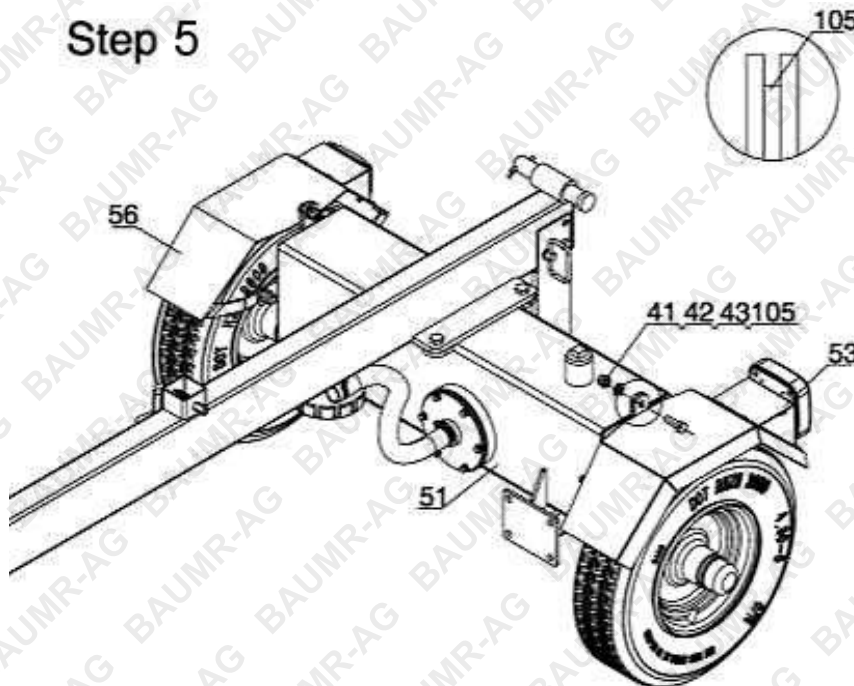

**Step 6: Attach the Engine Mounting Plate**

1. Attach engine mounting plate (#68) to the oil tank (#51) using hex bolt M10x30 (#41), flat washer Ø10 (#42) and lock nut M10 (#43).

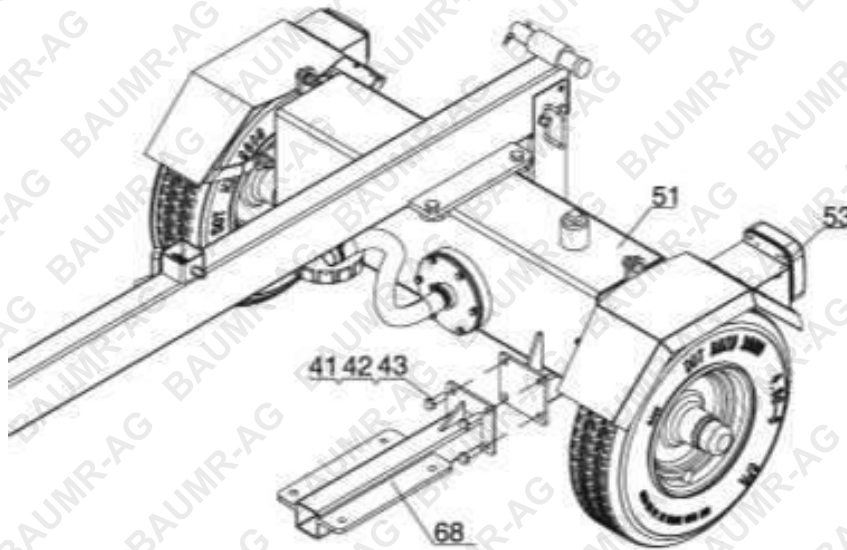

**Step 7: Attach the Beam**

1. Take down the hinge pin (#48) and cotter pin (#49), attach beam assembly to the tow bar using the hinge pin (#48) and cotter pin (#49).
2. Take down the plug on the hydraulic hose connector (#101), install the hydraulic hose (#101) as shown in the picture below.
3. Screw the handle (#115) to the beam.

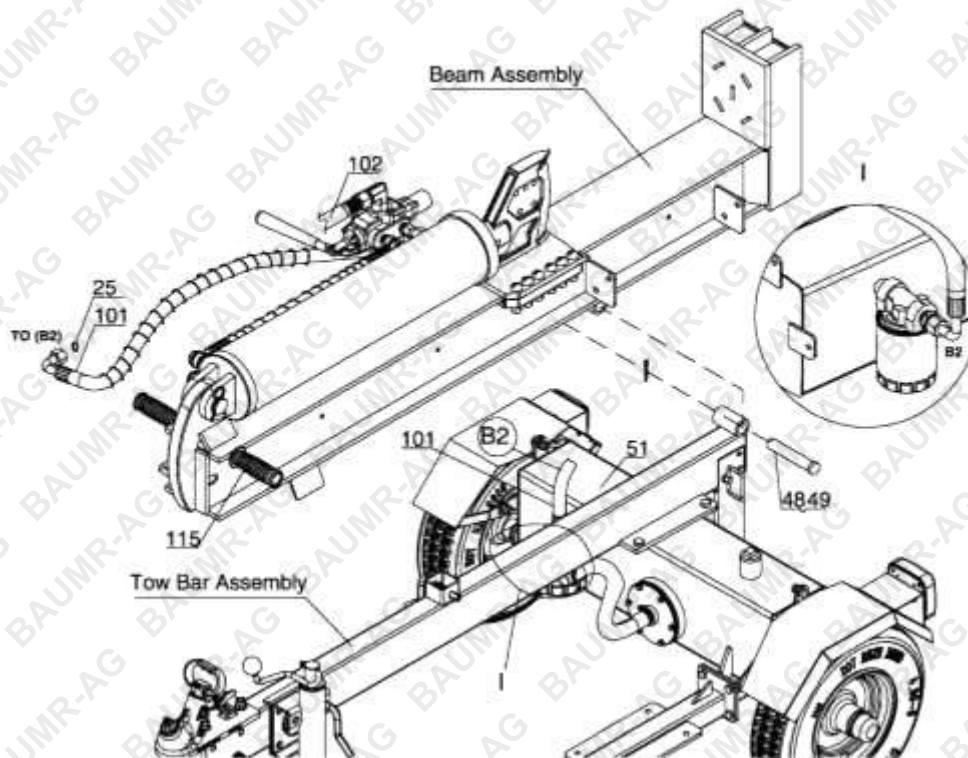

### Step 8: Attach the Gear Pump

1. Open the gear and pump package. Install the engine bushing (#95), flat key (#97) and engine coupler (#94) to the engine shaft in turns. Then attach the gear pump assembly (#91) to engine using hex bolt M8x25 (#86), lock washer Ø8 (#87) and flat washer Ø8 (#4). Fix the coupler cover (#99) by hex bolt M5x10 (#98).

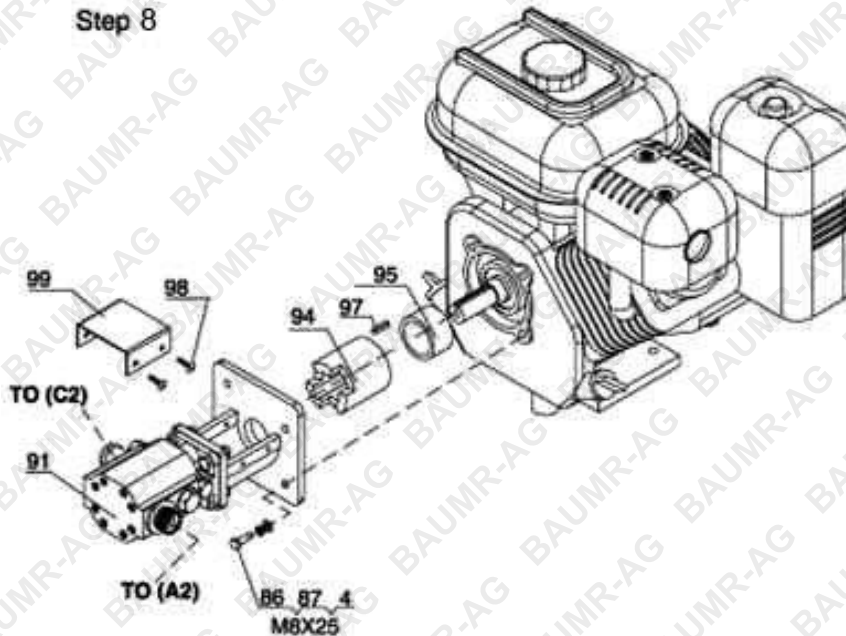

### Step 9: Attach the Engine and Oil Pipe

1. Attach the engine (#83) to the engine mounting plate using hex bolt M10x75 (#45), flat washer Ø10 (#42) and nylon lock nut M10 (#43).

**NOTE:** Put polyurethane block (#84) and block washer (#85) in between engine and mounting plate.

2. Connect the oil pipe (#104) to gear pump using clamp (#103) as shown in the picture.
3. Take down the plug on the hydraulic hose (valve-gear pump) (#102), connect the hydraulic hose (valve-gear pump) (#102) to the gear pump using o ring (#100) as shown in the picture.

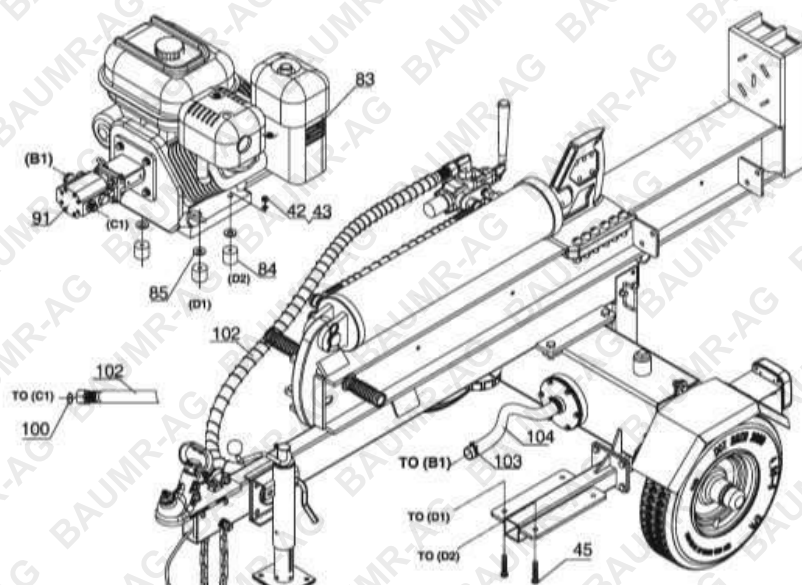

### Step 10: Attach the Wood Table and Log Cradle

1. Attach the log cradle (#28 & #40) to the beam using hex bolt M10x30 (#41), flat washer Ø10 (#42) and nylon lock nut M10 (#43).
2. Attach the wood table (#37) to the wood table mounting frame (#38) using hex bolt M8x35 (#39), flat washer Ø8 (#4) and nylon lock nut M8 (#5).
3. Insert the wood table assembly into the log cradle (#40).

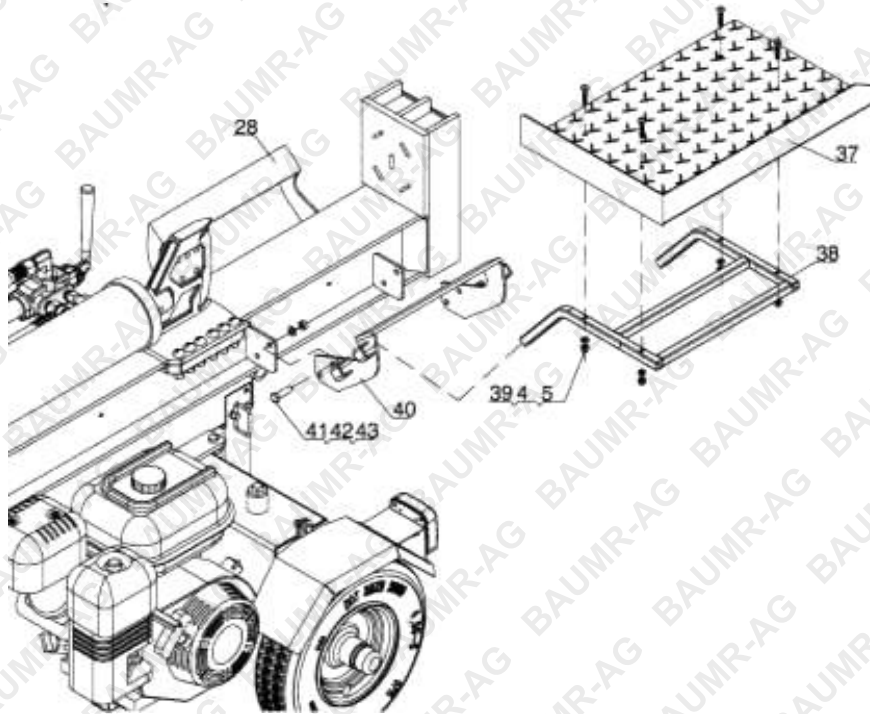

### Step 11: Attach the License Lamp

1. Attach the plug of the license lamp through the license mounting plate, then screw it with a bolt.

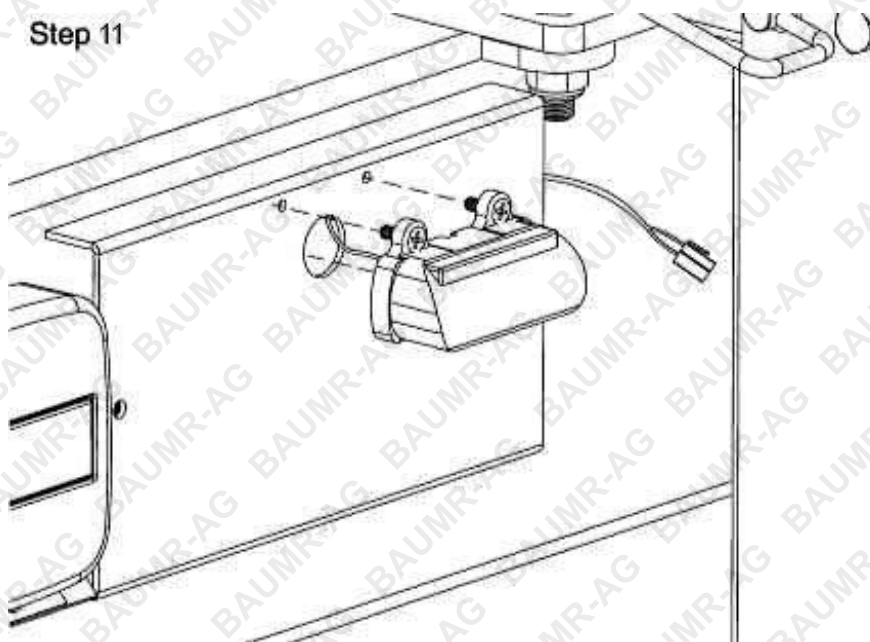

## Step 12: Wiring

1. Connect the joint according to the sign on the plug, connect L to L, R to R. connect the remaining pair of plug, fixed by cable.
2. Stick the self-adhesive wire clasps on the lamp line, tear the protection film, stick on the right place, install the plug and the redundant wire into the license mounting plate.

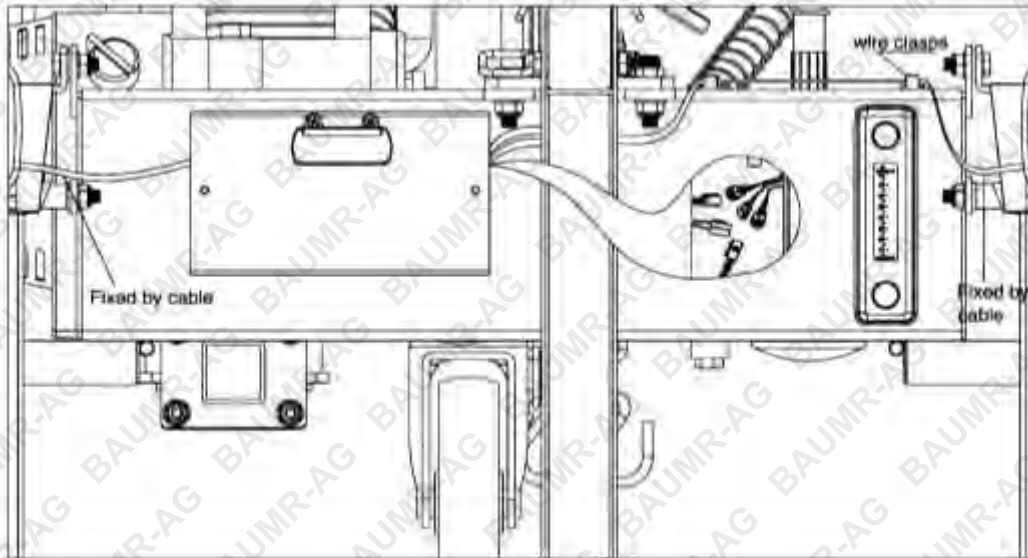

## Step 13: Attach the Cross Wedge

1. Attach the left and right cross wedge (#107 & #106) to the wedge using hex bolt M10x50 (#108) and hex lock nut M10 (#43).

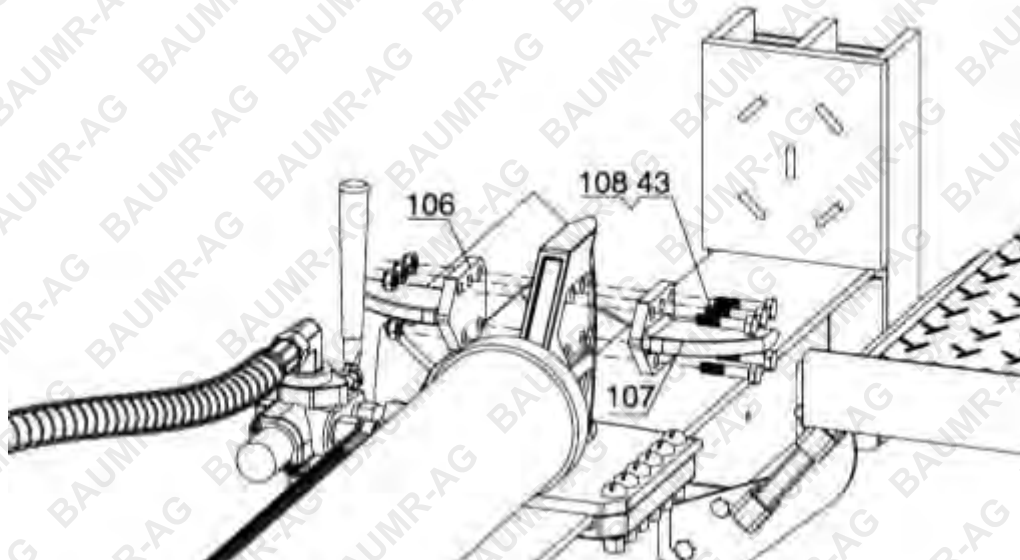

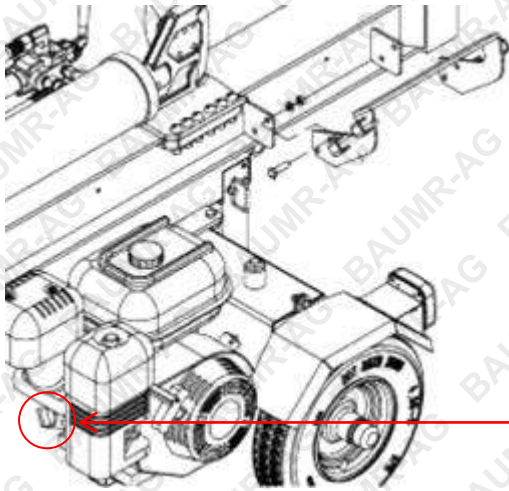
**Step 14: Add the Engine Oil**

Engine oil dip stick

1. Make sure that the log splitter is on a level surface.
2. Remove the engine oil dipstick to add oil.
3. Recommended Engine oils to use are; **10W-30, 10W-40 or 15W40**
4. Pour approximately **1.1 litres** into the engine.
5. Check engine oil level daily and add as needed.

**NOTE: During the break-in period check the engine oil level often.**

**CAUTION**

DO NOT attempt to crank or start the engine before it has been properly filled with the recommended type and amount of oil. Damage to the log splitter as a result of failure to follow these instructions will void your warranty.

**Step 15: Add Diesel Fuel to the Engine**

1. Use only clean, fresh, diesel fuel for the engine.
2. DO NOT mix oil with fuel.
3. Remove the fuel cap and slowly add fuel to the tank. DO NOT overfill; allow approximately ¼ inch of space for fuel expansion.
4. Screw on the fuel cap and wipe away any spilled fuel.

**DANGER**

- Log splitter engine exhaust contains carbon monoxide, a colourless, odourless, poison gas. Breathing carbon monoxide will cause nausea, dizziness, fainting or death. If you start to feel dizzy or weak, get to fresh air immediately!
- Operate the log splitter outdoors and only in well-ventilated areas.
- DO NOT operate the log splitter inside any building, enclosure or compartment.
- DO NOT allow exhaust fumes to enter a confined area through windows, doors, vents or other openings.
- **DANGER OF CARBON MONOXIDE!** Using a log splitter indoors **CAN KILL YOU IN MINUTES!**



**CAUTION**

- Fuel and its vapours are highly flammable and extremely explosive.
- Fire or explosion can cause severe burns or death.
- Unintentional start up can result in entanglement, traumatic amputation or laceration.
- Only use regular diesel fuel.
- DO NOT mix oil and diesel fuel together.
- Fill the tank approximately ¼" below the top of the tank to allow for fuel expansion.
- DO NOT fill the fuel tank indoors or when the engine is running or when it is hot.
- DO NOT light cigarettes or smoke when filling the fuel tank.

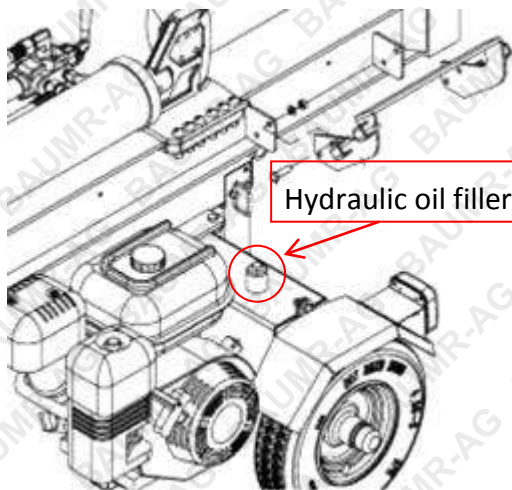
**Step 16: Add the Hydraulic Oil**

1. The log splitter needs to be on a flat, level surface before adding the hydraulic oil.
2. Remove the oil cap from the hydraulic oil tank.
3. Add approximately **30 litres** of hydraulic oil; **ISO 68 grade** is recommended.
4. Check the hydraulic oil level.
5. Start engine and use the control lever to extend and retract wedge several times to remove air from the lines.
6. With the wedge retracted, check hydraulic oil level again and fill if necessary.

**WARNING**

- DO NOT remove the hydraulic oil fill cap when the engine is running or when it is hot. Hot oil can escape, causing severe burns. Always allow the log splitter to cool completely before removing the hydraulic oil cap.
- High fluid pressure and temperatures are created in the hydraulic log splitters. Hydraulic fluid will escape through a pin-size hole opening and can puncture skin and cause severe blood poisoning.
- Inspect the hydraulic system regularly for possible leaks. **Never check for leaks with your hand while the system is pressurized. Seek medical attention immediately if injured by escaping fluid.**
- Make sure that all fittings are tight and secure before applying pressure. Relieve system pressure before servicing.
- Make sure that the hydraulic hoses do not touch any hot surfaces or cutting areas.
- Hoses need to be positioned where they are clear from the engine and cutting wedge. To avoid serious bodily injury always inspect the hoses before operating the log splitter.

# Operation Instructions



## WARNING

- Before operating or using the log splitter, review the instructions below and all safety information.
- Failure to follow these instructions may result in property damage or injury to the operator or bystanders.



## WARNING

- **ALWAYS** use the log splitter for its intended use.
- **ONLY** use the log splitter to split wood logs, length wise with the grain.
- **NEVER** modify, alter or change the log splitter in anyway, modifications will void the warranty.
- **NEVER** attach a rope, cable or other device to the control lever on the log splitter.
- **ONLY** operate the log splitter in daylight.
- **NEVER** leave the log splitter unattended while the engine is running.
- **DO NOT** change the splitting position with the engine running. Contact with the muffler can cause serious burns.
- **ALWAYS** make sure the beam is in the locked position.
- **DO NOT** let the beam drop as it could crush fingers or cause damage to the log splitter.
- **NEVER** operate or let anyone else operate, the log splitter while under the influence of alcohol, drugs, or medication.

## Using Your Log Splitter

1. DO NOT at any time carry passengers, sit or stand on the log splitter.
2. Check the hydraulic oil level and visually inspect all hoses and attachments for problems.
3. Inspect the engine and make sure that the engine oil level is correct.
4. Before towing the log splitter, the tires need to be fully inflated.



## TIRE WARNING

- DO NOT over-inflate the tires. Serious injury can result if the tires explode
- DO NOT tow the log splitter if the tires are worn or will not hold air.
- DO NOT exceed the maximum 45 MPH towing speed.

5. Refer to the vehicle owner's manual for proper safety and towing instructions.



## TOWING WARNING

- Serious injury or death can occur if towing safety rules are not followed.
- Always check the ball coupler and wheels to make sure all hardware is secure before towing.
- Before towing a long distance, check to make sure that the axle nuts and pins are tight and securely in place.

# Preparations for Starting

**Fuel tank**  
Use diesel light oil. Take care not to enter dust and water into the fuel and the fuel tank.

Cap  
Red plug

**Air cleaner element**  
Do not wash the air cleaner element because this is a wet type element. When the engine output tends to drop or the exhaust colour changes adversely, replace the element. Do not perforate the element and never run the engine without it.

**Engine Speed lever**

Stop  
Start/Run

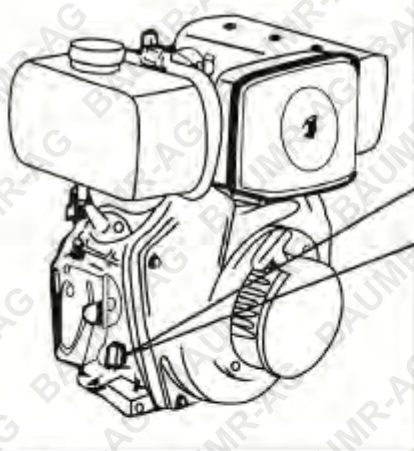
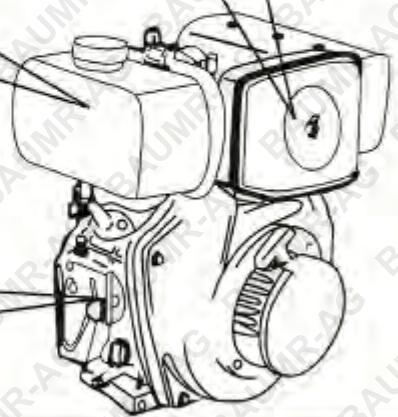

**Lube Oil Filler Port**  
Fill the Oil up to the mouth of the filler port with the engine placed on the level. When checking the Oil, simply dip the dipstick into the Oil pan. Do not screw in the dipstick.

**ENGINE OIL**  
We recommend A.P.I engine service classification of CC or CD. Always use oil with the right viscosity for the ambient temperature in which your engine is being operated. Use the chart mentioned right side when choosing your engine oil.

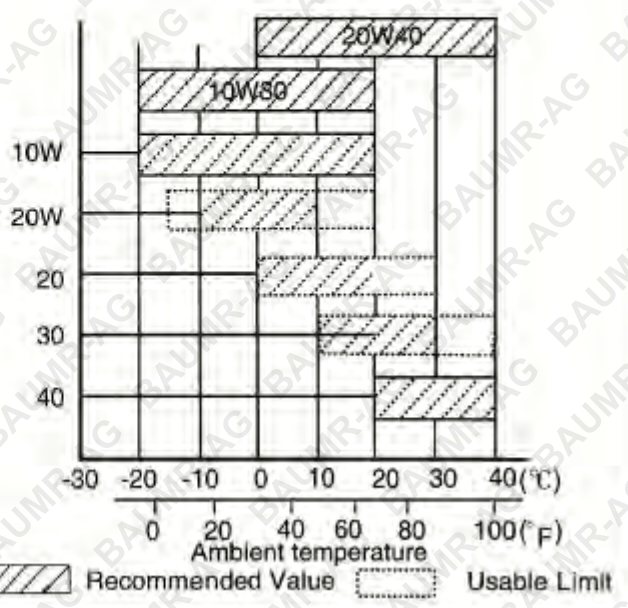
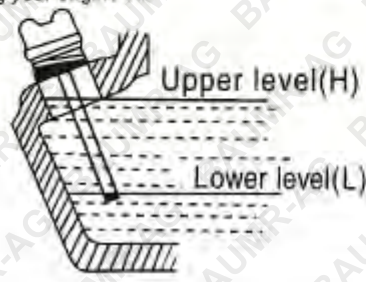

Plastic plug  
In cold weather,when the engine is hard to start,remove the plastic plug and add 2cc of engine oil, put the plug back in place.  
NOTE:  
Always keep the plastic plug in place. If it is removed,the engine will suck in dust and be damaged.

Decompression lever  
Do not use decompression lever to stop the engine.

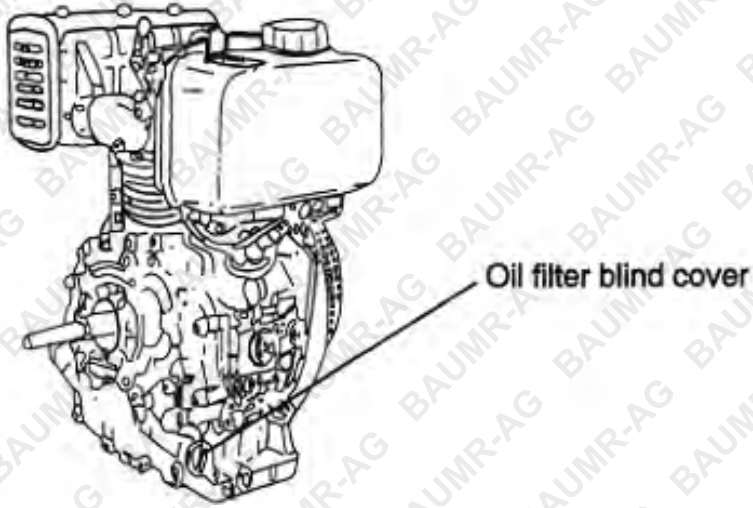
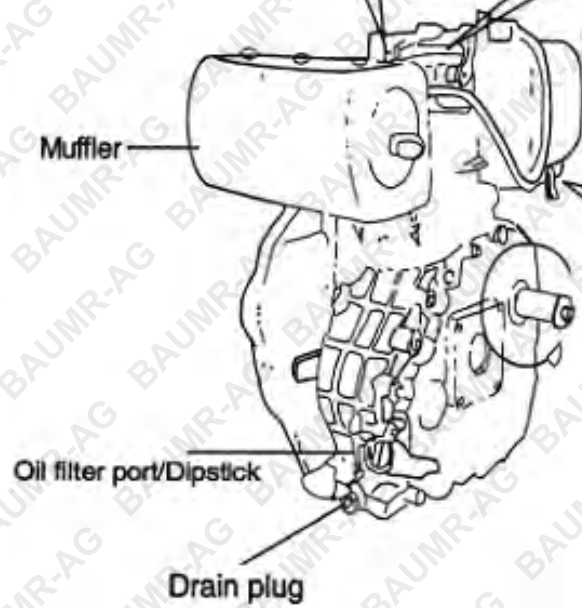

# How to Start Your Engine

## Recoil Starting

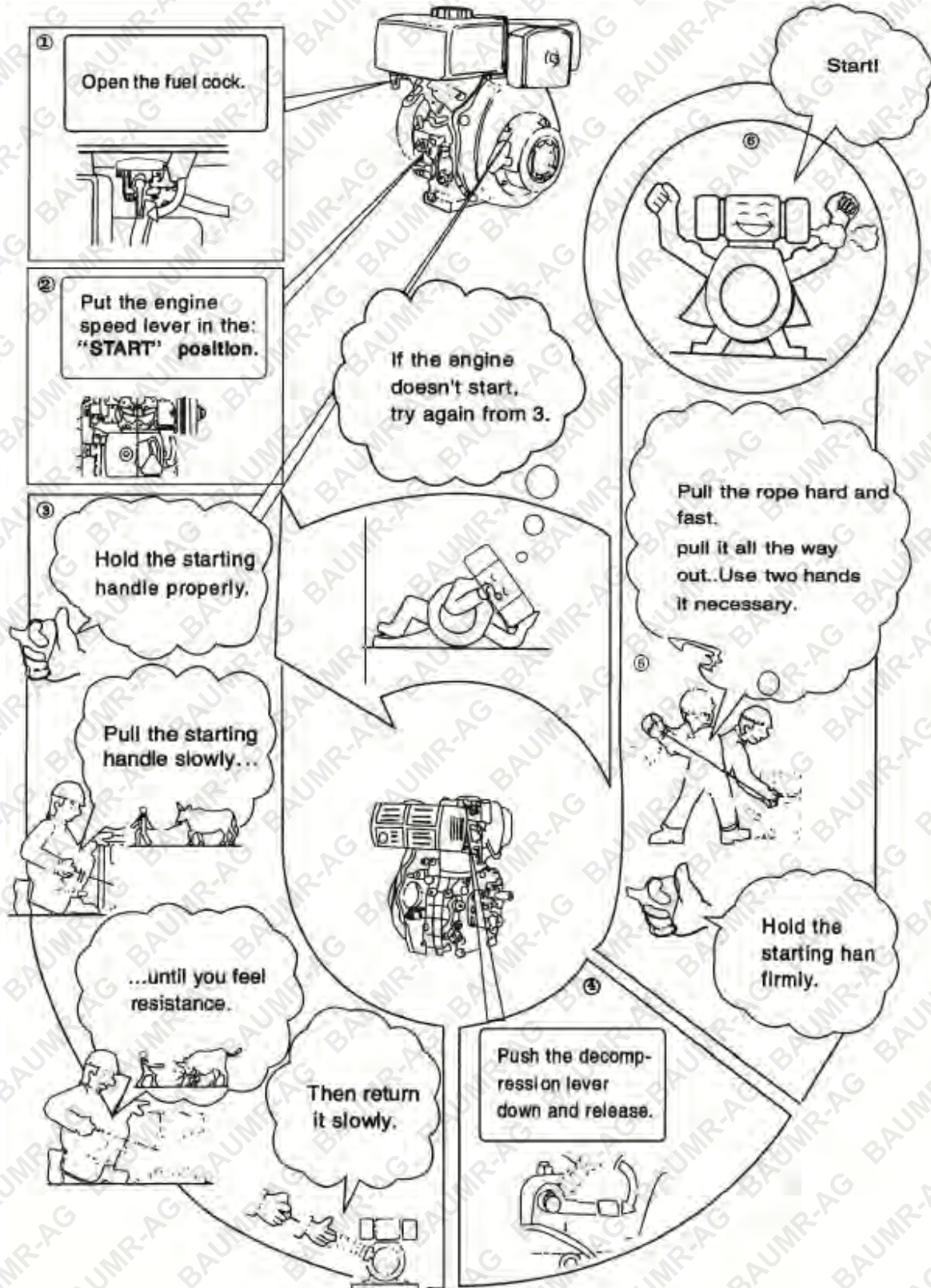

**X**

For ③, don't pull the rope too fast or too hard.



**O**

Always pull the rope slowly.

1. Open the fuel cock.

2. Put the engine speed lever in the "START" position.

3. If the engine doesn't start, try again from 1.

4. Hold the starting handle properly.

5. Pull the starting handle slowly.

6. If you feel resistance, then return to step 1.

7. Push the device reason lever down and release.

8. Hold the starting fan firmly.

9. That the rope fixed and then pull it all the way out. Use two hands if necessary.

Start

**X**

For ⑤, if you don't pull the rope all the way out, the engine won't start.



**O**

Always pull the rope all the way out.



**X**

For ⑤, if you don't pull hard enough, the engine won't start.



**O**

Always pull the rope hard and fast.



- Always use safety chains, secure and lock the log splitter to the vehicle hitch before moving.
- Drive safely. Be aware of the added length of the log splitter.
- Never exceed the maximum travel speed of 45 mph.
- Never ride or transport cargo on the log splitter.
- Turn off the vehicle before leaving the log splitter unattended.
- Block the log splitter wheels to prevent unintended movement.

6. The log splitter must have at least seven feet of clearance from combustible material. It needs to be on a dry and level surface with good footing. Do not work on mud, ice, brush or snow. When using the log splitter, the work zone must be cleanly-maintained at all times.

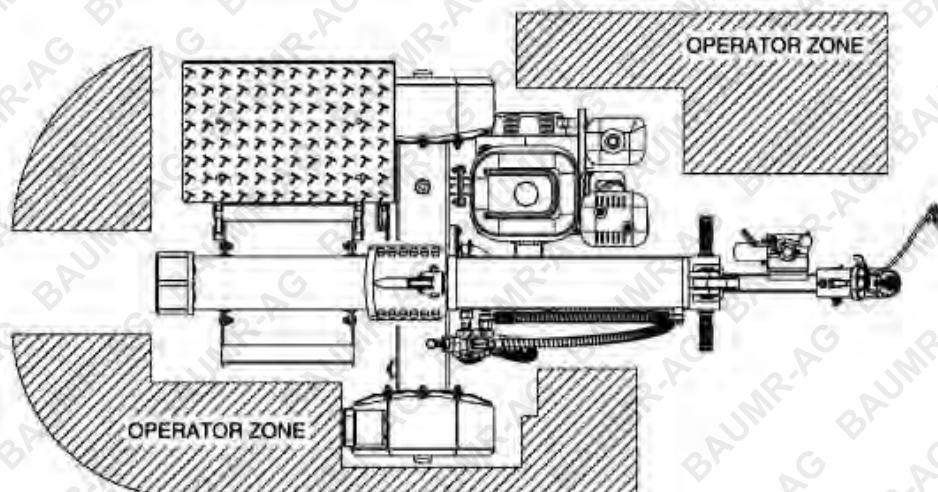

**NOTE: Serious accidents can happen when other people are allowed inside the work zone. Keep everyone else outside the work zone while operating the control lever.**

7. Always wear safety gear, eye protection, gloves and work boots when operating the log splitter
8. Start the engine and make sure the log splitter is on level ground before operating.

**NOTE: The hydraulic oil needs to be above 10°F (-12°C) before starting the engine. Cold hydraulic oil can damage the hydraulic pump. If outdoor air temperature is below 32°F (0°C), allow the log splitter to warm up by extending and returning the wedge several times before splitting wood.**

9. Put both support legs in the down position to prevent the log splitter from moving during operation and block both tires.
10. Set the log splitter in horizontal position.

**NOTE: HORIZONTAL position is used for lighter logs that can easily be loaded onto the beam. Back injury can result from lifting logs onto the log splitter if proper lifting techniques are not used.**

11. Load a log onto the beam against the endplate (Max Log Length – 21.65")

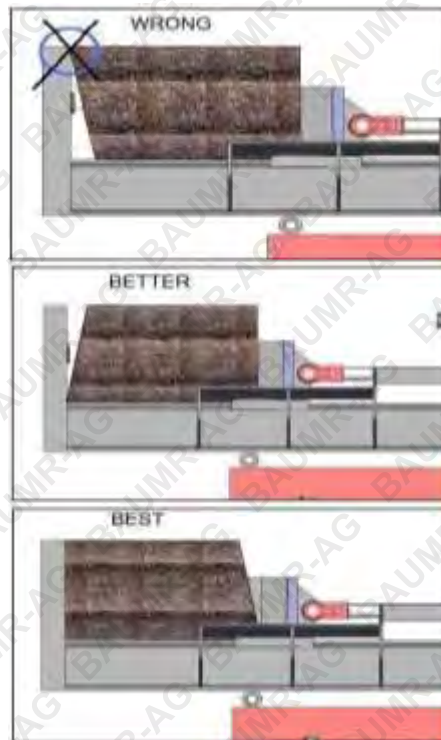

12. Make sure that hands are clear from the wedge and crush hazard areas.



#### CRUSH WARNING

- Wedge can cut through skin and break bones. Keep both hands away from wedge and beam slide.
- Serious accidents can happen when other people are allowed inside the work zone. Keep everyone else out of the work zone while operating control lever.
- DO NOT wear loose clothing. It can get tangled in the moving parts of log splitter.
- Only use the log splitter in daylight so you can see what you are doing.

13. Push control lever FORWARD by one hand to split the log.

14. Push control lever BACKWARD by one hand to return wedge to its original position



#### CAUTION

- If a log gets stuck, embedded or will not split completely, push the control lever in the reverse direction and allow the splitter to strip the log from the wedge.
- If the log still remains stuck, embedded or will not split, turn the machine off and use a sledge hammer and crow bar to remove the log.
- ALWAYS keep hands clear of the log and wedge while it is retracting.

15. Always keep work zone clean and free of split wood and debris.



# Maintenance and Storage



## WARNING

Improper maintenance and storage of the log splitter may void your warranty.

## Maintenance

- Before performing maintenance, the log splitter must be placed in maintenance mode. Turn off the engine and move the control lever forward and backwards to relieve the hydraulic pressure.
- After performing any maintenance, make sure that all guards, shields and safety features are put back in place before operating the log splitter.
- Before operating, make sure that the tires have the **RECOMMENDED TIRE PRESSURE**.
- Regularly grease the axle and wheel bearing area or when needed.
- After the wheel bearings have been greased, make sure that the axle nuts and pins are in place and secure.
- Periodically check all fasteners and hoses for tightness and leaks.
- Annually clean and lightly lubricate all moving parts or when needed.
- Use a glossy enamel spray paint to touch up scratched or worn painted metal surfaces.
- Never exceed load capacity rating of 50 tons it will damage the log splitter.

What	When	How
Hoses	Each Use	Inspect hoses for exposed wire mesh and leaks. Replace all worn or damaged hoses before starting the engine.
Hydraulic Fittings	Each Use	Inspect fittings for cracks and leaks. Replace all damaged fittings before starting the engine.
Nuts and Bolts	Each Use	Check for loose bolts, tighten before operating.
Beam	Each Use	Apply grease to beam surface.
Moving Parts	Each Use	Clear debris from log splitter.

**Refer to the Engine Owner's Manual for engine maintenance.**

### **IMPORTANT:**

- If a part needs replacement, only use parts that meet the manufacturer's specifications. Replacement parts that do not meet specifications may result in a safety hazard or poor operations.

### Storage

- Before storing, make sure that the log splitter is clean and dry for years of trouble free service.
- Lightly lubricate all log splitter surfaces and moving parts to prevent rust.
- Store indoors or protected area during severe weather and winter months.

# Troubleshooting

## Problem

Cylinder rod will not move	SOLUTION: A, D, E, H, J
Slow cylinder rod speed when extending or retracting	SOLUTION: A, B, C, H, I, K, L
Wood will not split or splits extremely slowly	SOLUTION: A, B, C, F, I, K
Engine bogs down during splitting	SOLUTION: G, L
Engine stalls under low load condition	SOLUTION: D, E, L, M

## Cause

## Solution

<b>A</b> – Insufficient oil to pump	Check oil level in reservoir
<b>B</b> – Air in oil	Check oil level in reservoir
<b>C</b> – Excessive pump inlet vacuum	Check pump inlet hose for blockage or kinks
<b>D</b> – Blocked hydraulic lines	Flush and clean the splitter hydraulic system
<b>E</b> – Blocked control valve	Flush and clean the splitter hydraulic system
<b>F</b> – Low control valve setting	Adjust control valve with a pressure gauge
<b>G</b> – High control valve setting	Adjust control valve with a pressure gauge
<b>H</b> – Damaged control valve	Return control valve for authorized repair
<b>I</b> – Internal control valve leak	Return control valve for authorized repair
<b>J</b> – Internal cylinder leak	Return cylinder for authorized repair
<b>K</b> – Internally damaged cylinder	Return cylinder for authorized repair
<b>L</b> – Engine Control out of adjustment	Adjust idle control nuts
<b>M</b> – Engine is loaded during idle down mode	Use shorter log length (24" or less) to allow engine to speed up before contact.

# Specifications

<b>Starting System:</b>	Recoil
<b>Fuel Tank Capacity:</b>	6.5L
<b>Fuel Type:</b>	Diesel
<b>Engine Oil Capacity:</b>	1.1L
<b>Pump Type:</b>	16GPM Two-Stage
<b>Hydraulic Hose:</b>	Benmar®
<b>Hydraulic Oil Capacity:</b>	22 L
<b>Hydraulic Oil Type:</b>	10WT AW32, ASLE H-150 or ISO32
<b>Max. Spitting Length:</b>	550mm
<b>Max. Tested Splitting Force (tons):</b>	50
<b>Rated Splitting Force (tons):</b>	35
<b>Max. Ram Travel:</b>	495mm
<b>Diameter of Ram:</b>	140mm
<b>Log Diameter:</b>	Up to 650mm
<b>Cycle Time:</b>	18s
<b>Wheel Diameter:</b>	16 inches pneumatic with bearing
<b>Jockey Wheel Diameter:</b>	8 inches

## Size and Weight

<b>Package Dimension:</b>	(L x W x H): 1910mm x 83mm x 54mm
<b>Gross Weight:</b>	336 kg

# Parts Drawing and Parts List

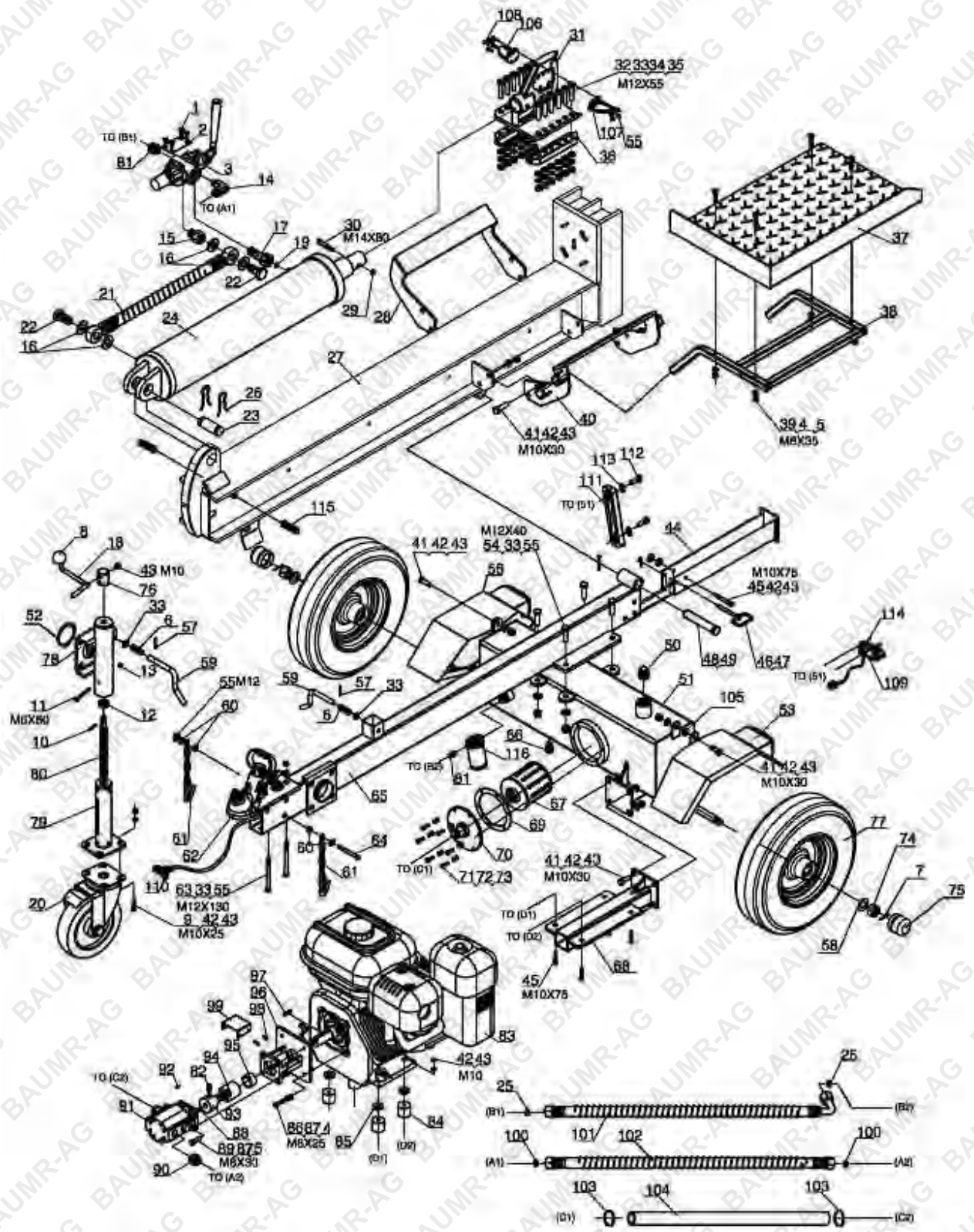

**50 Ton Diesel Log Splitter****Bäumr-AG**

Ref#	Drawing No.	Description	Qty.
1	9110-08010-DX	Screw M8x10	4
2	LSA22-00025	Plate	1
3	LSM30-05000	Control Valve	1
4	9301-08000-DX	Flat Washer Ø8	8
5	9206-08000-DX	Hex Lock Nut M8	8
6	LSP25-00003-DX	Spring	2
7	9404-04036-DX	Cotter Pin 4x36	2
8	LSE20-07001	Handle Ball	1
9	9101-10025-DX	Hex Bolt M10x25	4
10	9402-05030-DX	Round Pin 5x30	1
11	9101-06060-DX	Hex Bolt M6x60	1
12	9608-51102	Thrust Ball Bearing	1
13	9206-06000-DX	Nylon Lock Nut M6	1
14	LST37-00012	Right Angle Connector	1
15	LST37-00003	Valve A Joint	1
16	9905-20000	Combination Washer Ø20	4
17	LSP25-17000	Combination Connector	1
18	LST37-00013	Lift Handle	1
19	9901-15*2.5	O Ring Ø15x2.5	1
20	LST37-14000	Universal Caster	1
21	LST37M-00007	Hose (valve-cylinder)	1
22	LST37-00002	Bolt Connector	2
23	LSP30-00004-DX	Cylinder Pin	1
24	LST37-07000	Cylinder	1
25	9901-17*2.5	O Ring 17x2.5	2
26	LSP25-00005-DX	R Pin	2
27	LST37M-01000	Beam	1
28	LST37-03000	Right Log Cradle	1
29	9206-14000-DX	Hex Lock Nut M14	1
30	9101-14080-DX8.8	Hex Bolt M14x80	1
31	LST37-05000	Wedge	1
32	9117-12055-DX12.9	Screw M12x55	12

## 50 Ton Diesel Log Splitter

# Bäumr-AG

Ref#	Drawing No.	Description	Qty.
33	9301-12000-DX	Flat Washer Ø12	20
34	9306-12000-DX	Lock Washer Ø12	12
35	9210-12000-DX	Hex Thick Nut M12	12
36	LST37-00005	Wedge Spacer	2
37	LST37-00001	Wood Table	1
38	LST37-11000	Wood Table Mounting Frame	1
39	9101-08035-DX	Hex Bolt M8x35	4
40	LST37-02000	Left Log Cradle	1
41	9101-10030-DX8.8	Hex Bolt M10x30	18
42	9301-10000-DX	Flat Washer Ø10	27
43	9206-10000-DX	Hex Lock Nut M10	33
44	LSA22-15000	Rear Support Leg	1
45	9101-10075-DX8.8	Hex Bolt M10x75	5
46	LSA22-16000	Handle Ring	1
47	LSP25-00012	R Pin	1
48	LSA22-00015-DX	Hinge Pin	1
49	9404-04040-DX	Cotter Pin 4x40	1
50	LSP25-13001-DX	Oil Bolt	1
51	LST37M-10000	Oil Tank	1
52	9304-62000-FH	Circlip for shaft	1
53	LST37M-12000	Left Fender	1
54	9101-12040-DX8.8	Hex Bolt M12x40	4
55	9206-12000-DX	Hex Lock Nut M12	7
56	LST37M-13000	Right Fender	1
57	9404-03030-DX	Cotter Pin 3x30	2
58	9301-20000-DX	Flat Washer Ø20	2
59	LSP25-00008-DX	Safety Pin	2
60	9399-12000-DX	Thick Flat Washer Ø12	4
61	LSA22-13000	Hook Chain	2
62	Z105	50MM Coupler	1
63	9101-12130-DX8.8	Hex Bolt M12x130	2
64	9101-12100-DX8.8	Hex Bolt M12x100	1

**50 Ton Diesel Log Splitter****Bäumr-AG**

Ref#	Drawing No.	Description	Qty.
65	LST37M-06000	Tow Bar	1
66	LSP25-00010-DX	Oil Plug	1
67	LSP30-00007	Oil Filter	1
68	LST37M-04000	Engine Mounting Plate	1
69	LSP30-00006	Rubber Washer	1
70	LSP30-15000-DX	Filter Mounting Plate	1
71	9101-06020-DX8.8	Hex Bolt M6x20	6
72	9306-06000-DX	Lock Washer Ø6	6
73	9301-06000-DX	Flat Washer Ø6	6
74	LSP25-00020-FH	Hex Slotted Nut M20	2
75	LSP25-00009-DX	Axle Cap	2
76	NS10-02002-DX	Lift Handle Bushing	1
77	LST37M-14000	Wheel	2
78	LST37-08000	Outer Tube	1
79	LST37-09000	Lift Tube	1
80	NS10-02001	Lift Screw	1
81	LST37-00016	Oil Return Connector	2
82	9121-06010-FH	Inner Hex Screw	1
83	YQ-XK15.0A-HE	Engine	1
84	LSP35-00001	Polyurethane Block	4
85	9302-10000-DX	Big Flat Washer Ø10	4
86	9101-08025-DX8.8	Hex Bolt M8x25	4
87	9306-08000-DX	Lock Washer Ø8	8
88	LSP25-10008-FH	Wire Snap Rings for Shaft	1
89	9101-08030-DX8.8	Hex Bolt M8x30	4
90	LST37-00014	Gear Pump Outlet Connector	1
91	LSP30-10001	Gear Pump 13/1.8	1
92	8801-3x3x25	Flat Key	1
93	LSP25-10003	Gear Pump Coupler	1
94	LSP25-10002	Engine Coupler	1
95	LSP25-1004-DX	Engine Bushing	1
96	LSP25-10005	Gear Pump Stand	1



**50 Ton Diesel Log Splitter****Bäumr-AG**

Ref#	Drawing No.	Description	Qty.
97	8801-7x7x40	Flat Key 7x7x40	1
98	9101-05010-DX8.8Q	Hex Bolt M5x10	4
99	LSP25-10006	Coupler Cover	1
100	9901-13*2.5	O Ring 14x2.5	2
101	LST37M-00006	Hydraulic Hose (valve-oil tank)	1
102	LST37M-00008	Hydraulic Hose (valve-gear pump)	1
103	LSP25-00011-DG	Clamp	2
104	LST37-00011	Oil Pipe	1
105	LSA22-00021	Rubber Washer 2	6
106	LST37M-00018	Right Wedge	1
107	LST37M-00017	Left Wedge	1
108	9101-10050-DX12.9	Hex Bolt M10x50	5
109	LST37M-16000	License Lamp	1
110	LST37M-15000	Plug	1
111	LST37M-02000	Oil Level Gauge	1
112		Oil Level Gauge Bolt	2
113	BS/A17.7*12.4*2	Combination Washer M12	2
114	9107-05016-DX	Screw M5x16	2
115	N600-00003	Handle	2
116	LSP25-09000	Oil Return Filter	1



**Some experts believe the incorrect or prolonged use of almost any product could cause serious injury or death. For information that may reduce your risk of serious injury or death consult the points below and additionally, the information available at [www.datastreamserver.com/safety](http://www.datastreamserver.com/safety)**

- Consult all documentation, packaging and product labelling before use. Note that some products feature online documentation which should be printed and kept with the product.
- Check product for loose / broken / damaged / missing parts, wear or leaks (if applicable) before each use. Never use a product with loose / broken / damaged / missing parts, wear or leaks (if applicable).
- Products must be inspected and serviced (if applicable) by a qualified specialist every 6 months assuming average residential use by a person of average weight and strength, above average technical aptitude, on a property matching average metropolitan specification. Intended use outside these guidelines could indicate the product is not suitable for intended use or may require more regular inspection or servicing.
- Ensure all possible users of the product have completed an industry recognised training course before being given access to the product.

- The product has been supplied by a general merchandise retailer that may not be familiar with your specific application or your description of the application. Be sure to attain third party approval for your application from a qualified specialist before use regardless of prior assurances by the retailer or its representatives.
- This product is not intended for use where fail-safe operation is required. As with any product (take an automobile, aircraft, computer or ball point pen for example) there is always a small chance of a technical issue that needs to be repaired or may require replacement of the product or a part. If the possibility of such failure and the associated time it takes to rectify could in any situation inconvenience the user, business or employee or could financially affect the user, business or employee then the product is not suitable for your requirements. This product is not for use where incorrect operation or a failure of any kind, including but not limited to a condition requiring product return, replacement, service by a technician or replacement of parts could cause a financial loss, loss of employee time or an inconvenience requiring compensation.
- If this item has been purchased in error considering the points above simply contact the retailer directly for details of their returns policies if required.

**Bäumr-AG**<sup>®</sup>  
.com.au