

Barbell and weights assembly instruction

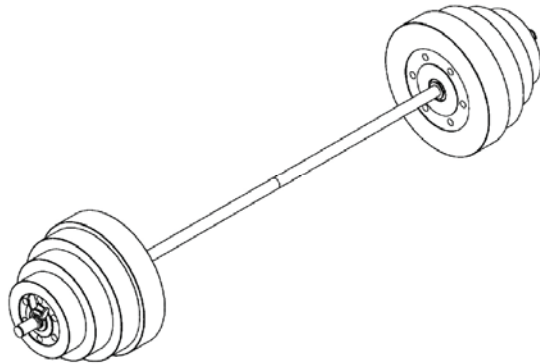

FOLDABLE WEIGHT LIFTING BENCH

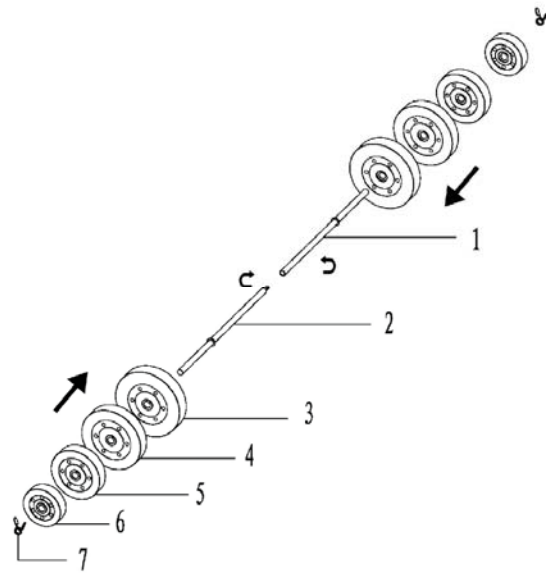
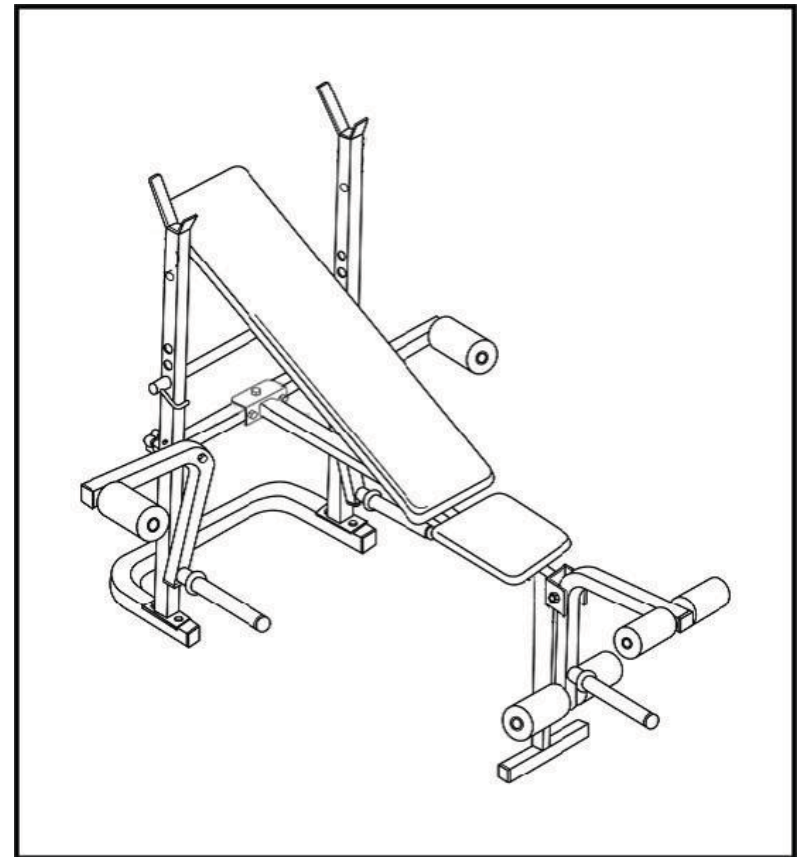

Important Safety Information

Please keep this manual in a safe place for reference.

1. It is important to read this entire manual before assembling and using the equipment. Safe and efficient use can only be achieved if the equipment is assembled, maintained and used properly. It is your responsibility to ensure that all users of the equipment are informed of all warnings and precautions.
2. Before starting any exercise program you should consult your doctor to determine if you have any physical or health conditions that could create a risk to your health and safety, or prevent you from using the equipment properly. Your doctor's advice is essential if you are taking medication that affects your heart rate, blood pressure or cholesterol level.
3. Be aware of your body's signals. Incorrect or excessive exercise can damage your health. Stop exercising if you experience any of the following symptoms: Pain, tightness in your chest, irregular heartbeat, extreme shortness of breath, feeling light headed, dizzy or nauseous. If you do experience any of these conditions you should consult your doctor before continuing with your exercise program.
4. Keep children and pets away from the equipment. The equipment is designed for adult use only.
5. Use the equipment on a solid, flat level surface with a protective cover for your floor or carpet. For safety, the equipment should have at least 0.5 metre of free space all around it.
6. Before using the equipment, check the nuts and bolts are securely tightened. Some parts like pedals, etc., it's easy to be wared away.
7. The safety level of the equipment can only be maintained if it is regularly examined for damage and/or wear and tear.
8. Always use the equipment as indicated. If you find any defective components whilst assembling or checking the equipment, or if you hear any unusual noise coming from the equipment during use, stop. Do not use the equipment until the problem has been rectified.
9. Wear suitable clothing whilst using the equipment. Avoid wearing loose clothing which may get caught in the equipment or that may restrict or prevent movement. Please run it slowly in the beginning. Please hold the handlebar tightly and do not let your body leave the seat when exercise.
10. The equipment has been tested and certified to EN957 under class H.C. Suitable for domestic, home use only. Maximum weight of user, 100kg. Breaking is speed independent.
11. The equipment is not suitable for therapeutic use.
12. Care must be taken when lifting or moving the equipment so as not to injure your back. Always use proper lifting techniques and/or use assistance.

EXERCISE INSTRUCTIONS

Using your EXERCISE CYCLE will provide you with several benefits, it will improve your physical fitness, tone muscle and in conjunction with calorie controlled diet help you lose weight.

1. The Warm Up Phase

This stage helps get the blood flowing around the body and the muscles working properly. It will also reduce the risk of cramp and muscle injury. It is advisable to do a few stretching exercises as shown below. Each stretch should be held for approximately 30 seconds, do not force or jerk your muscles into a stretch - if it hurts, STOP.



2. The Exercise Phase

This is the stage where you put the effort in. After regular use, the muscles in your legs will become more flexible. Work to your own pace but it is very important to maintain a steady tempo throughout. The rate of work should be sufficient to raise your heart beat into the target zone shown on the graph below.

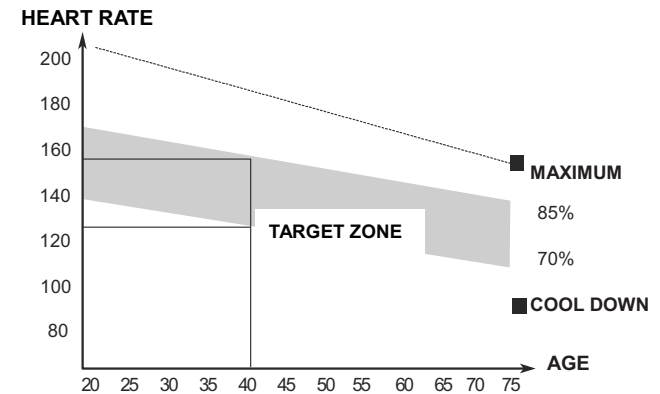

This stage should last for a minimum of 12 minutes though most people start at about 15-20 minutes

3. The Cool Down Phase

This stage is to let your Cardio-vascular System and muscles wind down. This is a repeat of the warm up exercise e.g. reduce your tempo, continue for approximately 5 minutes. The stretching exercises should now be repeated, again remembering not to force or jerk your muscles into the stretch. As you get fitter you may need to train longer and harder. It is advisable to train at least three times a week, and if possible space your workouts evenly throughout the week.

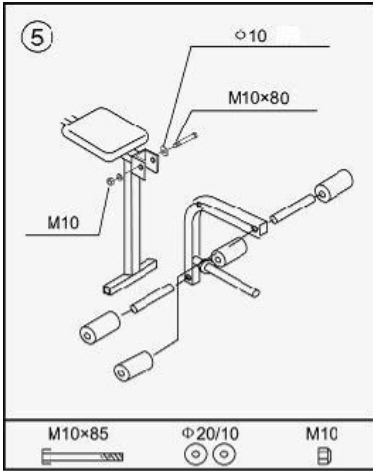

Bolt the leg Extension Bracket to the Front Leg using the Thicker Bolt and two Washers. Slide the Round Tubes into the hole provided. Push the Foam Pads onto the tube.

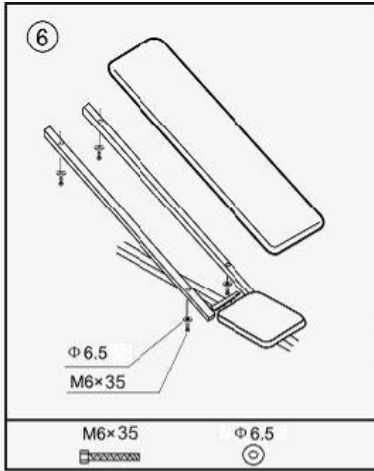

Slide the Backrest Frames onto the pivot Bar on the Cross Bar, then screw the Backrest to frames.

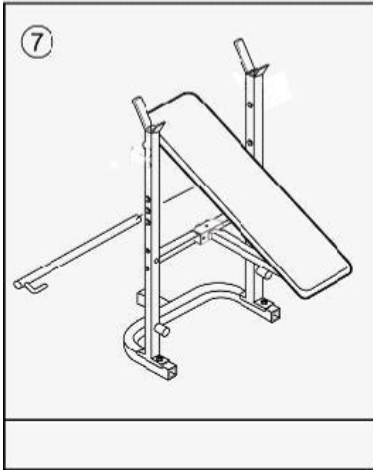

Insert the bar into the holes in the Upright Frames.

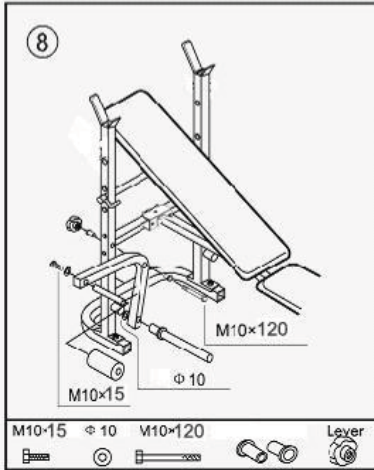



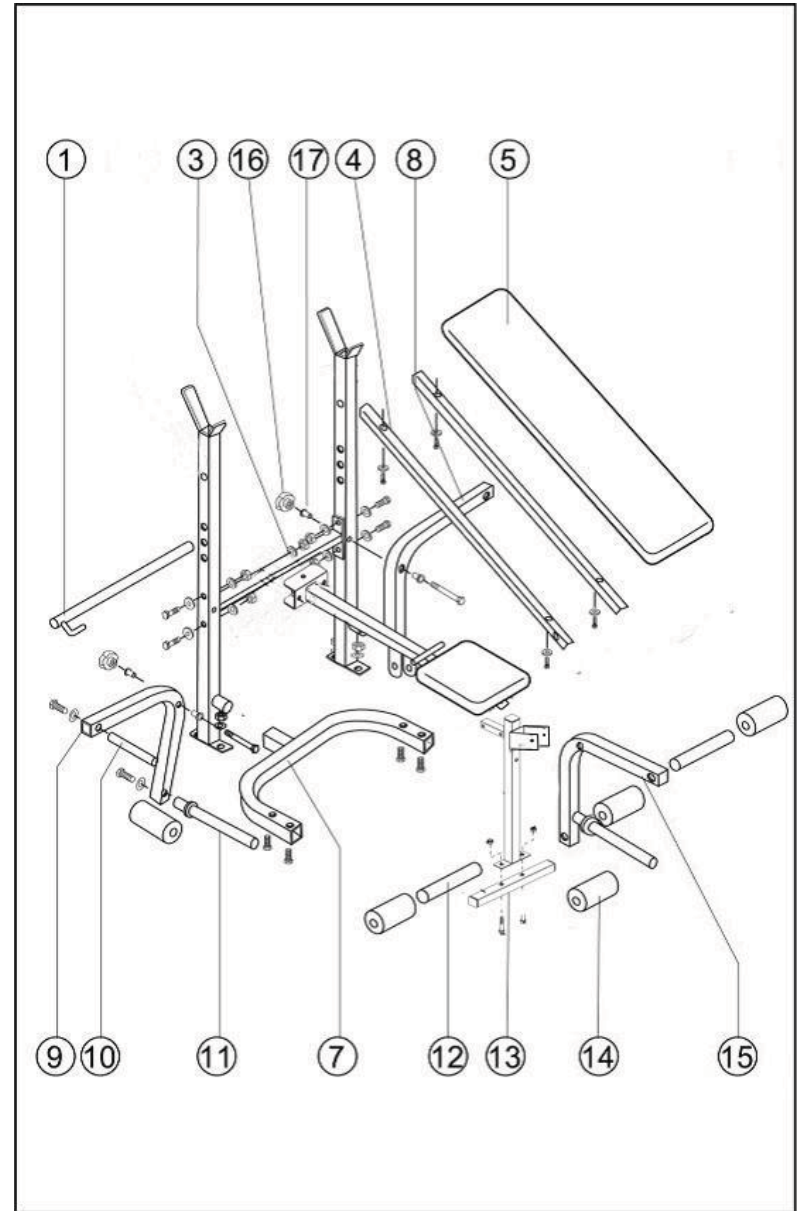





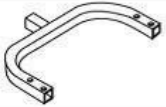

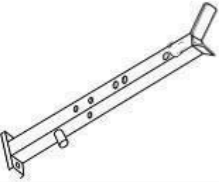

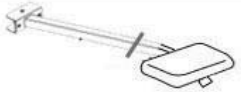
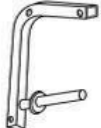

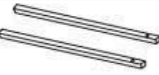









Assemble the two fly arms(9) first, bolts the Round tubes(11) (10) to the arms(8,9) with The M10x20 bolts. Push the form pads Onto the form tubes(10). Attach the fly Arms to the upright post with M10x130mm Bolts, metal bushes(17) and levers(16)



CHECK LIST

Please check off each part on the check list before beginning the assembly of your bench.

	1	<input type="checkbox"/>		1	<input type="checkbox"/>
	2	<input type="checkbox"/>		1	<input type="checkbox"/>
	1	<input type="checkbox"/>		1	<input type="checkbox"/>
	1	<input type="checkbox"/>		2	<input type="checkbox"/>
	1	<input type="checkbox"/>		6	<input type="checkbox"/>
	1	<input type="checkbox"/>		2	<input type="checkbox"/>
	1	<input type="checkbox"/>	 M8×40	2	<input type="checkbox"/>
	1	<input type="checkbox"/>	 M10×15	4	<input type="checkbox"/>
			 M8	15	<input type="checkbox"/>
			 M10×120	2	<input type="checkbox"/>
			 M10	2	<input type="checkbox"/>
			 M10×80	1	<input type="checkbox"/>
			 $\Phi 6.5$	8	<input type="checkbox"/>
			 M10×130	1	<input type="checkbox"/>
			 $\Phi 8.5$	15	<input type="checkbox"/>
			 M6×35	4	<input type="checkbox"/>
			 $\Phi 10$	8	<input type="checkbox"/>
			 M6×15	4	<input type="checkbox"/>
			 M8×45	4	<input type="checkbox"/>
			M8×40	2	<input type="checkbox"/>

ASSEMBLY

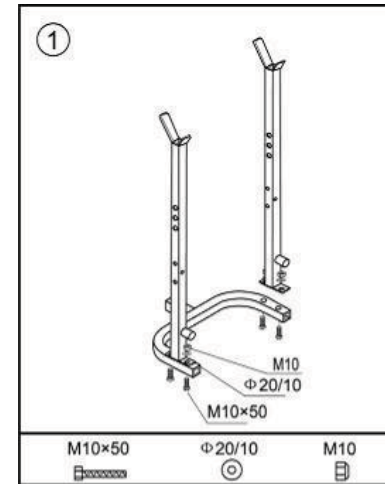

1) Bolt the two uprights(2) to the rear base(7).

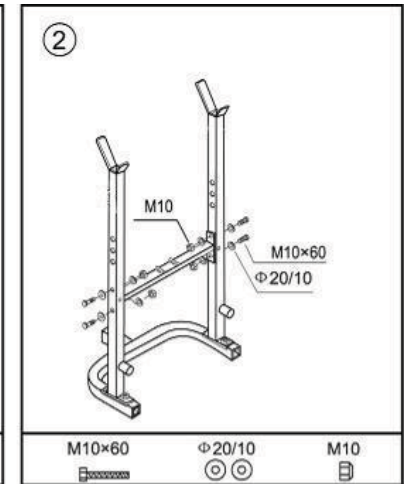

2) Bolt the cross bar(3) in between the two uprights.

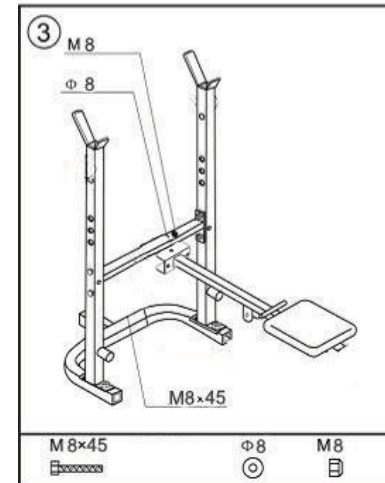

Bolt the main beam(6) to the center of the cross bar(3).insert the pull pin to hole of the cross bar.

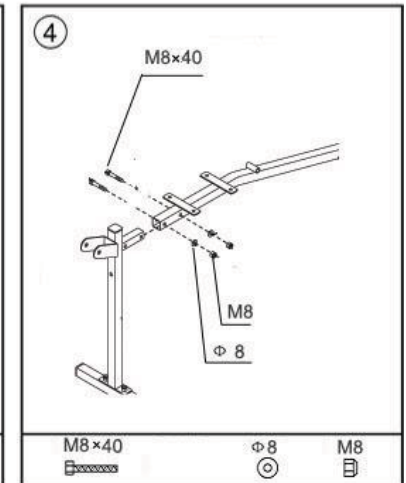

Bolt the T-Front Leg to main beam. Then insert pull pin into the hole of the main beam.



Some experts believe the incorrect or prolonged use of almost any product could cause serious injury or death. For information that may reduce your risk of serious injury or death consult the points below and additionally, the information available at www.datastreamserver.com/safety

- Consult all documentation, packaging and product labelling before use. Note that some products feature online documentation which should be printed and kept with the product.
- Check product for loose / broken / damaged / missing parts, wear or leaks (if applicable) before each use. Never use a product with loose / broken / damaged / missing parts, wear or leaks (if applicable).
- Products must be inspected and serviced (if applicable) by a qualified specialist every 6 months assuming average residential use by a person of average weight and strength, above average technical aptitude, on a property matching average metropolitan specification. Intended use outside these guidelines could indicate the product is not suitable for intended use or may require more regular inspection or servicing.
- Ensure all possible users of the product have completed an industry recognised training course before being given access to the product.

- The product has been supplied by a general merchandise retailer that may not be familiar with your specific application or your description of the application. Be sure to attain third party approval for your application from a qualified specialist before use regardless of prior assurances by the retailer or its representatives.
- This product is not intended for use where fail-safe operation is required. As with any product (take an automobile, aircraft, computer or ball point pen for example) there is always a small chance of a technical issue that needs to be repaired or may require replacement of the product or a part. If the possibility of such failure and the associated time it takes to rectify could in any situation inconvenience the user, business or employee or could financially affect the user, business or employee then the product is not suitable for your requirements. This product is not for use where incorrect operation or a failure of any kind, including but not limited to a condition requiring product return, replacement, service by a technician or replacement of parts could cause a financial loss, loss of employee time or an inconvenience requiring compensation.
- If this item has been purchased in error considering the points above simply contact the retailer directly for details of their returns policies if required.

