



Radiant Heat Panel Spectra 18, 24 and 32



User Manual

[Revision 1.0 June 2018]

READ THIS MANUAL CAREFULLY BEFORE USE – FAILURE TO DO SO MAY RESULT IN INJURY, PROPERTY DAMAGE AND MAY VOID WARRANTY. • KEEP THIS MANUAL FOR FUTURE REFERENCE. • Products covered by this manual may vary in appearance, assembly, inclusions, specifications, description and packaging.

Safety

Safety messages are designed to alert you to possible dangers or hazards that could cause death, injury or equipment or property damage if not understood or followed. Safety messages have the following symbols:

 You WILL be KILLED or SERIOUSLY INJURED if you do not follow instructions.	 You CAN be KILLED or SERIOUSLY INJURED if you do not follow instructions.	 You CAN be INJURED if you do not follow instructions or equipment damage may occur.
<p>It is vital that you read and understand this user manual before using the product, including safety warnings, and any assembly and operating instructions. Keep the manual for future reference.</p> <p>Safety precautions and recommendations detailed here must be fully understood and followed to reduce the risk of injury, fire, explosion, electrical hazard, and/or property damage.</p> <p>Safety information presented here is generic in nature – some advice may not be applicable to every product. The term "equipment" refers to the product, be it electrical mains powered, battery powered or combustion engine powered.</p> <ul style="list-style-type: none"> • Before Use - If you are not familiar with the safe operation/handling of the equipment, or are in any way unsure of any aspect of suitability or correct use for your application, you should complete training conducted by a person or organization qualified in safe use and operation of this equipment, including fuel/electrical handling and safety. • Do NOT operate the equipment in flammable or explosive environments, such as in the presence of flammable liquids, gases or dust. The equipment may create sparks or heat that may ignite flammable substances. • Keep clear of moving parts. • Equipment may be a potential source of electric shock or injury if misused. • Do NOT operate the equipment if it is damaged, malfunctioning or is in an excessively worn state. • Do NOT allow others to use the equipment unless they have read this manual and are adequately trained. • Keep packaging away from children - risk of suffocation! Operators must use the equipment correctly. When using the equipment, consider conditions and pay due care to persons and property. <p>General Work Area Safety</p> <ul style="list-style-type: none"> • Work areas should be clean and well lit. • Do not operate the equipment if bystanders, animals etc are within operating range of the equipment or the general work area. • If devices are provided for connecting dust extraction / collection facilities, ensure these are connected and used properly. Dust collection can reduce dust-related hazards. 	<p>General Personal Safety</p> <ul style="list-style-type: none"> • Wear appropriate protective equipment when operating, servicing, or when in the operating area of the equipment to help protect from eye and ear injury, poisoning, burns, cutting and crush injuries. Protective equipment such as safety goggles, respirators, non-slip safety footwear, hard hat, hearing protection etc should be used for appropriate equipment / conditions. Other people nearby should also wear appropriate personal protective equipment. Do not wear loose clothing or jewellery, which can be caught in moving parts. Keep hair and clothing away from the equipment. • Stay alert and use common sense when operating the equipment. Do not over-reach. Always maintain secure footing and balance. • Do not use the equipment if tired or under the influence of drugs, alcohol or medication. • This equipment is not intended for use by persons with reduced physical, sensory or mental capabilities. <p>General Fuel Safety</p> <ul style="list-style-type: none"> • Petrol/fuel/gasoline is extremely flammable – keep clear of naked flames or other ignition sources. • Do not spill fuel. If you spill fuel, wipe it off the equipment immediately – if fuel gets on your clothing, change clothing. • Do NOT smoke near fuel or when refuelling. • Always shut off the engine before refuelling. • Do NOT refuel a hot engine. • Open the fuel cap carefully to allow any pressure build-up in the tank to release slowly. • Always refuel in well ventilated areas. • Always check for fuel leakage. If fuel leakage is found, do not start or run the engine until all leaks are fixed. <p>General Carbon-Monoxide Safety</p> <ul style="list-style-type: none"> • Using a combustion engine indoors CAN KILL IN MINUTES. Engine exhaust contains carbon-monoxide – a poison you cannot smell or see. • Use combustion engines OUTSIDE only, and far away from windows, doors and vents. 	<p>General Equipment Use and Care</p> <ul style="list-style-type: none"> • The equipment is designed for domestic use only. • Handle the equipment safely and carefully. • Before use, inspect the equipment for misalignment or binding of moving parts, loose components, damage or any other condition that may affect its operation. If damaged, have the equipment repaired by an authorised service centre or technician before use. • Prevent unintentional starting of the equipment - ensure equipment and power switches are in the OFF position before connecting or moving equipment. Do not carry equipment with hands or fingers touching any controls. Remove any tools or other items that are not a part of the equipment from it before starting or switching on. • Do not force the equipment. Use the correct equipment for your application. Equipment will perform better and be safer when used within its design and usage parameters. • Use the equipment and accessories etc. in accordance with these instructions, considering working conditions and the work to be performed. Using the equipment for operations different from those intended could result in hazardous situations. • Always keep equipment components (engines, hoses, handles, controls, frames, housings, guards etc) and accessories (cutting tools, nozzles, bits etc) properly maintained. Keep the equipment clean and, where applicable, properly lubricated. • Store the equipment out of reach of children or untrained persons. To avoid burns or fire hazards, let the equipment cool completely before transporting or storing. Never place or store the equipment near flammable materials, combustible gases or liquids etc. • The equipment is not weather-proof, and should not be stored in direct sunlight, at high ambient temperatures or locations that are damp or humid. • Do not clean equipment with solvents, flammable liquids or harsh abrasives. • For specific equipment safety use and care, see Equipment Safety.

<p>General Electrical Safety</p> <ul style="list-style-type: none"> Inspect electrical equipment, extension cords, power bars, and electrical fittings for damage or wear before each use. Repair or replace damaged equipment immediately. Ensure all power sources conform to equipment voltage requirements and are disconnected before connecting or disconnecting equipment. When wiring electrically powered equipment, follow all electrical and safety codes. Wherever possible, use a residual current device (RCD). High voltage / high current power lines may be present. Use extreme caution to avoid contact or interference with power lines. Electrical shock can be fatal. 	<p>General Electrical Safety</p> <ul style="list-style-type: none"> Electrically grounded equipment must have an approved cord and plug and be connected to a grounded electrical outlet. Do NOT bypass the ON/OFF switch and operate equipment by connecting and disconnecting the electrical cord. Do NOT use equipment that has exposed wiring, damaged switches, covers or guards. Do NOT use electrical equipment in wet conditions or in damp locations. Do NOT use electrical cords to lift, move or carry equipment. Do NOT coil or knot electrical cords, and ensure electrical cords are not trip hazards. 	<p>General Service Information</p> <ul style="list-style-type: none"> The equipment must be serviced or repaired at authorised service centres by qualified personnel only. Replacement parts must be original equipment manufacturer (OEM) to ensure equipment safety is maintained. Do NOT attempt any maintenance or repair work not described in this manual. After use, the equipment and components may still be hot – allow the equipment to cool and disconnect spark plugs and/or electrical power sources and/or batteries from it before making adjustments, changing accessories or performing repair or maintenance. Do NOT make adjustments while the equipment is running. Perform service related activities in suitable conditions, such as a workshop. Replace worn, damaged or missing warning/safety labels immediately.
<p>Beware of Children and Pets</p> <ul style="list-style-type: none"> Children should not be allowed to touch or operate heaters or touch extension cords, if used. All heaters should be kept out of reach of children, preferably stored or locked in a secure cabinet or room when not in use. <p>Do Not Abuse the Power Cord</p> <ul style="list-style-type: none"> Never yank or pull on the power cord to disconnect it from the mains supply socket. Never carry your heater by its' power cord. Keep the power cord away from heat, oil, solvents and sharp edges. Check the power cord regularly for any damage and if the power cord becomes damaged have it replaced by an authorised service facility. <p>Extension Cords and Reels</p> <ul style="list-style-type: none"> This heater is NOT designed to run off an extension cord. If you require an additional power point, please have one installed by a qualified electrician. The use of extension cords may cause power voltage loss which will result in damage to the appliance this will NOT be covered under warranty. 	<p>Installation</p> <ul style="list-style-type: none"> Always ensure you select the correct fixing accessories which suit the wall/ceiling material you are attaching to, if in doubt please discuss with your local retailer or local hardware store. This heater is not designed for use within 1m or above a water source. All installations must meet the requirements of Australia Standard AS/NZS 3000:2007. Ensure that the heater is not positioned directly above, below or in front of a power point or switch. This heater is not designed to be used with 3rd party timer or programmable system. <p>FOR YOUR SAFETY</p> <ul style="list-style-type: none"> WARNING: Fire risk exists if this heater is covered by or positioned close to curtains or other combustible materials. NOTE: If using this heater outside ensure that it is connected directly to an outdoor power point. The electrical system of this heater must be connected with an automatic 30mA circuit breaker and/or residual current device (RCD). If uncertain, have a qualified electrician check your electrical system before installation and/or use. All electrical connections are made in a dry area. Outdoor power points must be weatherproof and installed by a qualified electrician. We are not responsible for incorrectly chosen fixing accessories or any damage which may be caused by an incorrectly fitted wall heater. If required 15AMP power points must be installed by a qualified electrician. 	

Specific Safety Instructions



Do not use the heater in areas where there is a risk of explosion or fire from flammable gases. Ensure that the heating area is kept clear of combustible materials. Do not use the heater in damp areas, without suitable ventilation. This heater is not designed for use within 1m or above a water source. Do not place within one metre (1m) of any water source. Do not place directly in front of, below or above any power points or switches. Fire risk exists if this heater is covered by or positioned close to curtains or other combustible materials.

- This heater is intended for domestic/household use only.
- Always ensure that this heater is installed as per the requirements noted in Australian Standard AS/NZS 3000:2007.
- Always keep heater at least one metre (1m) from combustible materials.
- DO NOT locate this heater directly below, above or in front of the power supply socket or switch.
- DO NOT use this heater within 1 metre or above any water source.
- DO NOT use this heater in either the bathroom or ensuite without suitable ventilation.
- DO NOT use a 3rd party timer, or programmable system with this heater.
- DO NOT clean the heater while the heater is on or plugged into the mains power supply.
- DO NOT touch any part of the heater while on, hot surfaces may burn.
- DO NOT use the wall heater as a dryer.
- DO NOT attempt to modify the heater, power cord, power plug or the supplied accessories in any way.
- DO NOT expose the heater to rain, water, or use in damp wet conditions.
- NEVER cover this heater.
- NEVER carry the heater by its power supply cord.
- NEVER use with the power cord coiled, bundled up or tied up. Always extend fully before use.
- NEVER use the heater if any part of it is damaged.
- Ensure that the heater is disconnected from the mains supply when installing, cleaning or removing/installing.
- Ensure this heater is not left on when unattended.
- Ensure the heater is not used in areas where flammable gases are present, e.g. paint, petrol etc.
- Always turn the heater OFF at the unit switch and the power point switch when not in use for extended periods of time.
- Always allow the heater to cool, about one (1) hour after the heater has been turned off, before cleaning the heater.
- Always ensure that the power cord is fully extended and NOT in contact with any part of the heater.
- Always ensure that the heater is kept clean and free from dust.
- Only use this heater when securely attached to the wall/ceiling.





















Electrical Data



This product is fitted with a sealed electrical connection plug that is compatible with the heater, the mains supply for Australia and meets the requirements of international standards. This heater must be connected to a supply voltage that is equal to that stated on the rating label. If the mains connection plug or power cord becomes damaged it must be replaced with a complete assembly that is identical to the original, and this must be replaced by an authorised service centre. Always follow the Australian requirements for connection to the mains supply. If in doubt always consult a qualified electrician. Note: (3200W) requires installation of a 15AMP socket by a qualified electrician before use.

Safety Symbols

The product may have safety warning labels attached to it, explained below. Understand the symbols on your product and their meanings. If any stickers become unreadable, unattached etc, replace them.

 <p>Flammable Material Hazard Flammable liquids, gases or substances etc may present. Avoid ignition sources and open flames. Danger of fire.</p>	 <p>Read User Manual Read and fully understand product safety warnings, operation, procedures etc before using the product.</p>	 <p>Use Hand Protection Wear appropriate hand protection and take due care as the product or use of the product may present hand hazards.</p>	 <p>Carbon-Monoxide Hazard Do not use the product in confined areas or without adequate ventilation. Carbon-monoxide poisoning can be fatal.</p>
 <p>Electrocution / Electrical Shock Hazard High voltage or high current electricity may be present or required by the product. Take due care when handling electrical products, cables, plugs and leads. Electrical shock can be fatal.</p>	 <p>Toxic Fumes / Dust Hazard Using the product or by-products from use may produce fumes, smoke or particles that could be harmful if inhaled. Wear appropriate breathing protection and have adequate ventilation.</p>	 <p>Explosive Material Hazard Combustible liquids, gases or substances etc may be present. Avoid ignition sources and open flames. Danger of explosion.</p>	 <p>Cutting / Amputation Hazard The product may have blades, edges or mechanical devices that can cause severe cut injury to fingers, limbs etc. Take due care when handling and using the product.</p>
 <p>Crush Hazard The product may have blades, edges or mechanical devices that can cause severe crush injury to fingers, limbs etc. Take due care when handling and using the product.</p>	 <p>Single Operator Only The product must be operated by a single person only. More than one person operating the product may introduce additional hazards.</p>	 <p>Use Face Protection Wear appropriate full-face protection and take due care as the product or use of the product may present face and eye hazards.</p>	 <p>Use Foot Protection Wear appropriate foot protection and take due care as the product or use of the product may present foot hazards.</p>
 <p>Use Eye / Ear / Head Protection Wear appropriate eye and / or ear and / or head protection and take due care as the product or use of the product may present eye, hearing and head hazards.</p>	 <p>Running Hazard Do not run on or near the product as doing so may present a fall hazard.</p>	 <p>Diving Hazard Do not dive into the product as doing so may present a neck / head injury hazard.</p>	 <p>Adult Supervision Required Always supervise children and other users of a product to prevent drowning or injury.</p>
 <p>Skin Penetration / Puncture Hazard The product may produce pressure, emit liquids or objects that can cause severe injury to fingers, limbs, blood etc. Take due care when handling and using the product.</p>	 <p>Hot Surface Hazard Be aware that the product may produce high temperatures and hot surfaces that can cause burn injuries.</p>	 <p>Flying Debris Hazard Be aware that the product or use of the product may present hazards produced by flying debris. Wear appropriate clothing and protective devices.</p>	 <p>Moving Parts Hazard Be aware that the product contains or uses mechanical devices that move or rotate. Always wait for moving parts to stop fully before handling the product, adjusting, maintenance etc.</p>



 <p>Carbon-Monoxide Hazard Do not use the product in confined areas or without adequate ventilation. Carbon-monoxide poisoning can be fatal.</p>	 <p>Pull Hazard Be aware that the product contains or uses mechanical devices that can pull in objects and can cause severe injury to fingers, limbs etc. Take due care when handling and using the product.</p>	 <p>Slope / Fall Injury Hazard Be aware that using the product on sloping surfaces or in slippery conditions may present additional dangers from falls and contact with blades, moving parts, hot surfaces etc.</p>	 <p>"Slam Dunk" Warning Do NOT attempt "slam dunk" manoeuvres as this may result in severe injury due to falling, product breakage or collapse etc.</p>
 <p>Electrocution / Electrical Shock Hazard - Outdoor High voltage or high current electricity may be present or required by the product. Do NOT use in rain, damp or wet conditions. Electrical shock can be fatal.</p>	 <p>Electrocution / Electrical Shock Hazard - Disconnect High voltage or high current electricity may be present or required by the product. Always disconnect the product from the electrical supply before handling the product, adjusting, maintenance etc.</p>	 <p>Power Line Electrocution Hazard High voltage / high current power lines may be present. Use extreme caution to avoid contact or interference with power lines. Electrical shock can be fatal.</p>	 <p>"Kick-Back" Hazard High level of "kick-back" hazard that can cause the machine to suddenly rotate towards operator. Kick-back injury can be fatal.</p>
 <p>Winch Operator Position Hazard Do NOT stand between winch and load. Do NOT use winch to move people.</p>	 <p>Winch Lift Hazard Do NOT LIFT load vertically. Use machine to PULL only.</p>	 <p>Cable Hazard Ensure that load bearing cable is not kinked or knotted.</p>	 <p>Winch Cable Hazard Ensure that there is a minimum number of cable coils on winching mechanism.</p>
 <p>Winch Hook Hazard Carry hook to load – do NOT throw or run.</p>	 <p>Flash / Blinding Hazard Wear appropriate eye protection for welding. Direct exposure to weld arcs may cause permanent eye injury.</p>	 <p>Laser Hazard Laser may be in use – do NOT look directly at laser, or allow others to.</p>	



Table of Contents

Safety	2
Specific Safety Instructions	4
Electrical Data	4
Safety Symbols	5
Assembly	8
Heater Head.....	8
Mounting Heater	8
General Mounting Suggestions	8
Wall/Ceiling Bracket Assembly	8
Adjusting the Bracket Position	9
Tilting the Head.....	9
Heater Positioning.....	10
Operation	11
Maintenance	11
Specifications	12
Spectra 18.....	12
Spectra 24.....	12
Spectra 32.....	12

Assembly

Heater Head

Attach the heater rear bracket (B) to the heater body (A) using bolts, washers and nuts. You can either mount side or lengthways depending on the mounting surface.

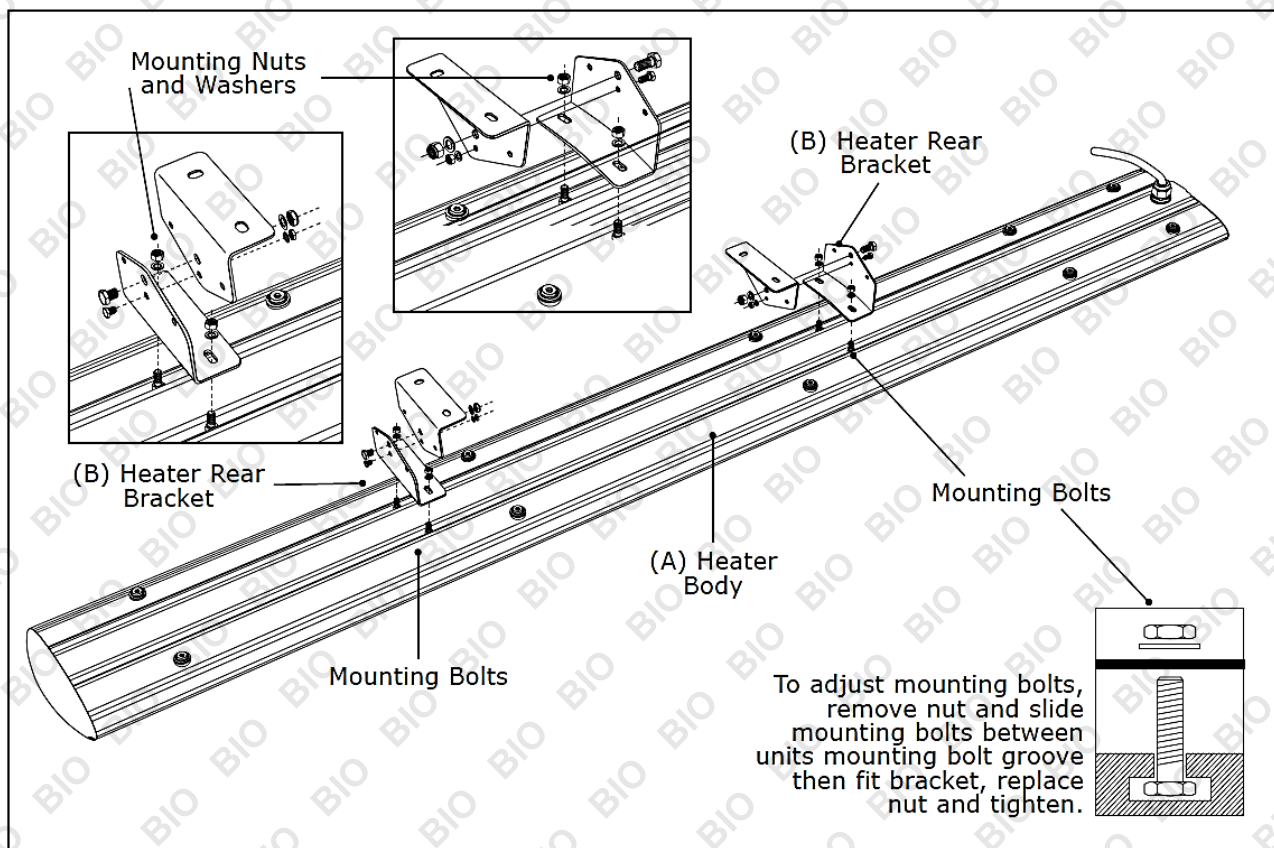

Mounting Heater

General Mounting Suggestions

If unsure, please discuss with your local hardware store.

- Ensure the fixing screws are at least suitable for 10Kg each.
- If fitting to a stud wall or ceiling, ensure all fixing screws are into timber. Plasterboard IS NOT suitable by itself.
- If no timber stud/joists are available we would suggest installing a timber batten to attach to.

Wall/Ceiling Bracket Assembly

1. The bottom of the heater body should be 1.8m above the floor, see [Heater Positioning](#).
2. Do not position the heater directly above or below a power point or switch. Do not position heater in front of a power point.
3. Mark and drill 2 mounting holes for bracket (C).
4. Using 2 suitable screws (not supplied) attach the bracket to the wall or ceiling.

Note: If unsure what screws to use, please discuss with your local hardware store.

5. Using the nuts and bolts join the bracket (C) to the heater bracket (B) and tighten fully.
6. Heater is now mounted and ready for use. Check the safety distance between the heater body and flammable surface when wall or corner mounted. Do not mount the heater in the ceiling, always mount to the ceiling, see [Heater Positioning](#).

Adjusting the Bracket Position

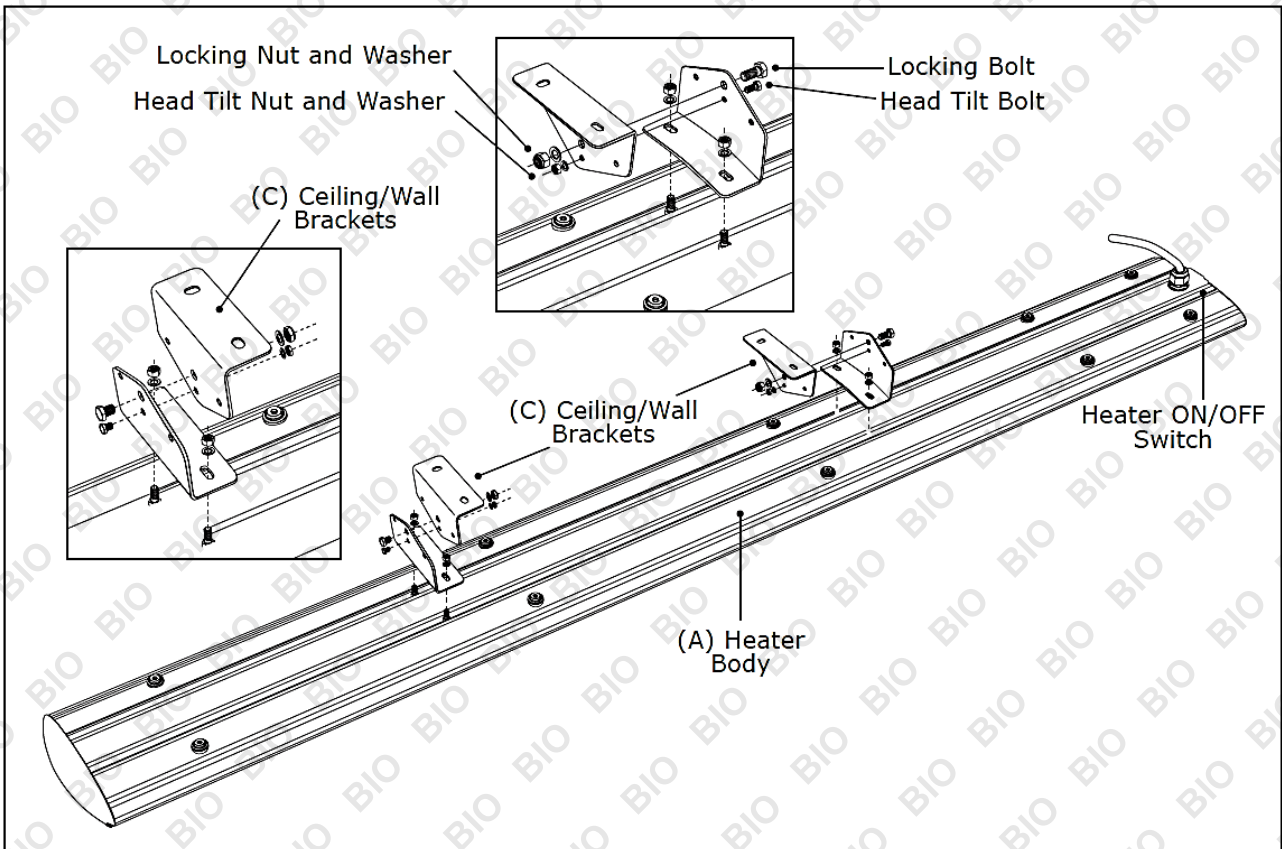

Tilting the Head



Always ensure that the heater is switched off, disconnected from the mains power supply and is cold to touch. If heater has been recently used, please leave the wall heater one (1) hour to cool before tilting head.

1. Loosen the locking bolt and remove.
2. Loosen the head tilt bolt, do not remove.
3. Head can be tilted through 30°.
4. Tighten the head tilt bolt when the desired angle is achieved.
5. Insert and tighten the locking bolt if possible to stop any unintentional movement of the heater.

Note: If locking bolt cannot be fitted, ensure the head tilt bolt is very tight.

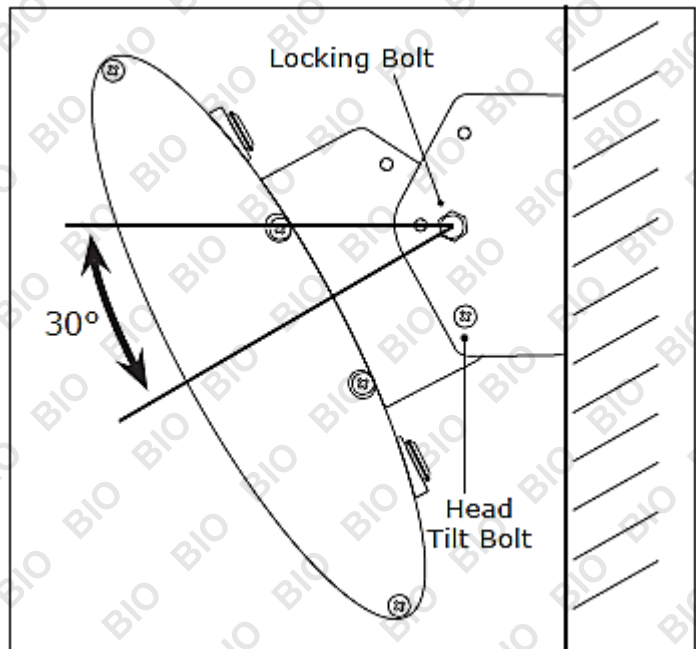

Heater Positioning

1. Position heater at least 200mm from the eave lining or ceiling or wall at 90° to heater.
2. Position heater at least 1.8m above the floor.
3. Never position in front, above or below a power point.
4. If heater is facing another vertical surface, e.g. a wall, the gap must be at least 1 metre.
5. Never mount heater within 1 metre of a water source, e.g. a tap.



Never mount heater into the wall or ceiling. Only mount to the surface.

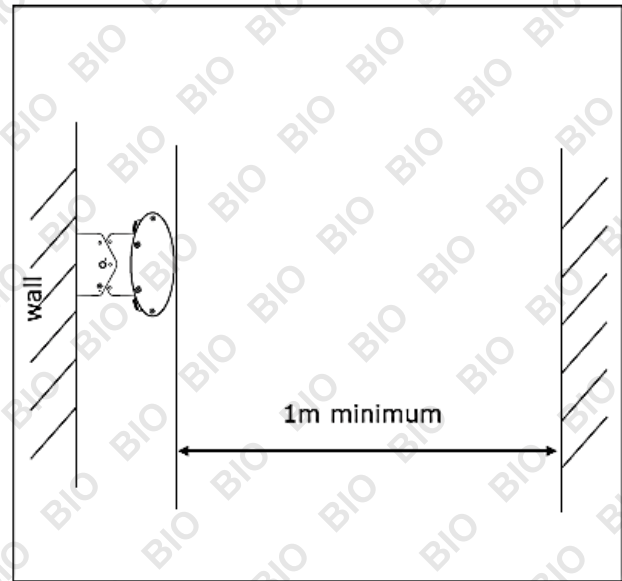
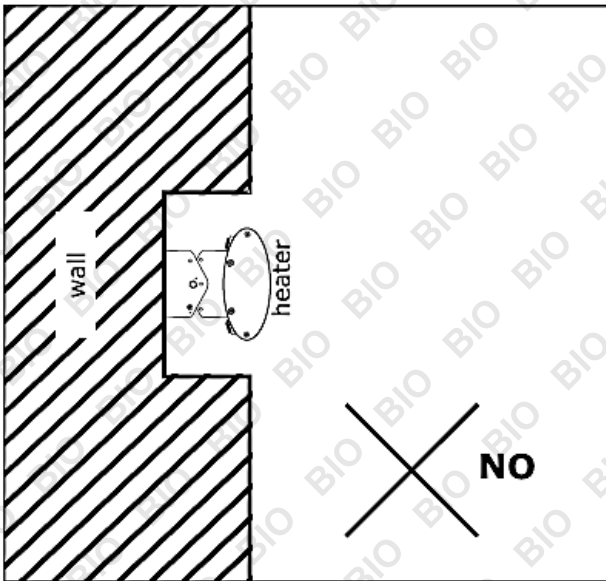
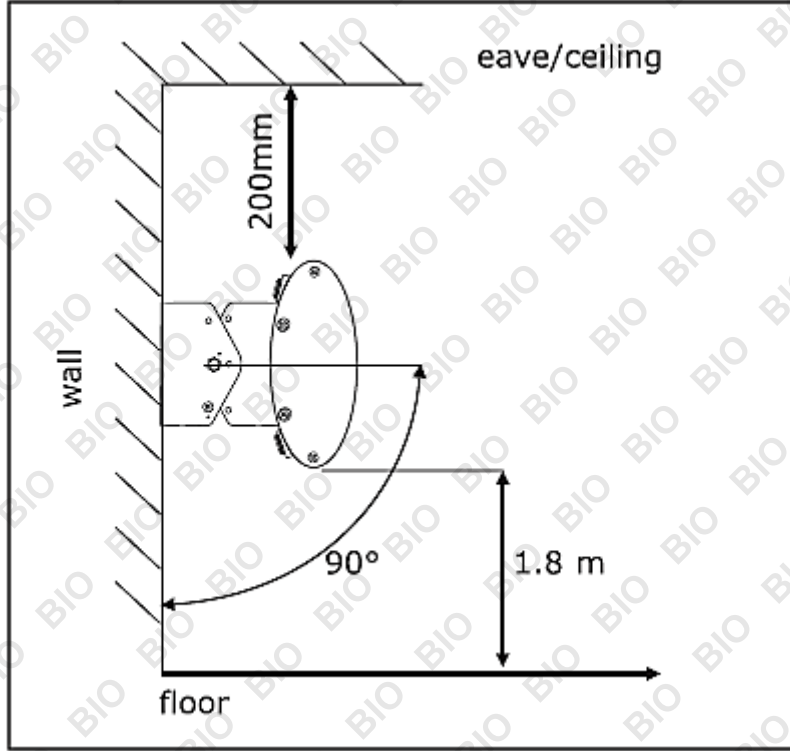

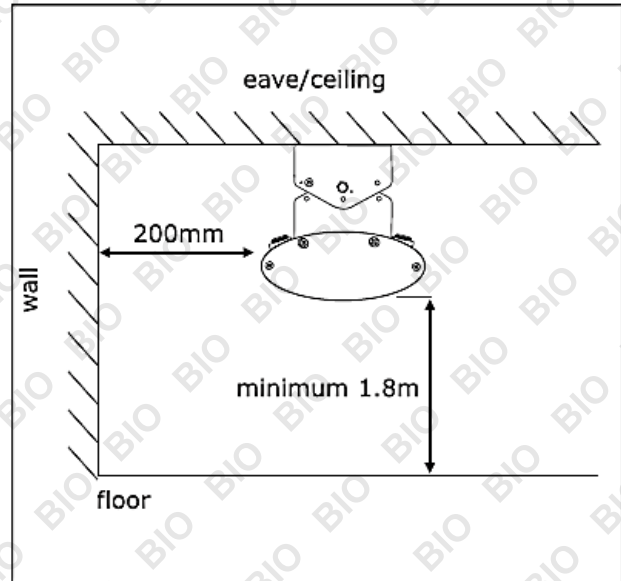
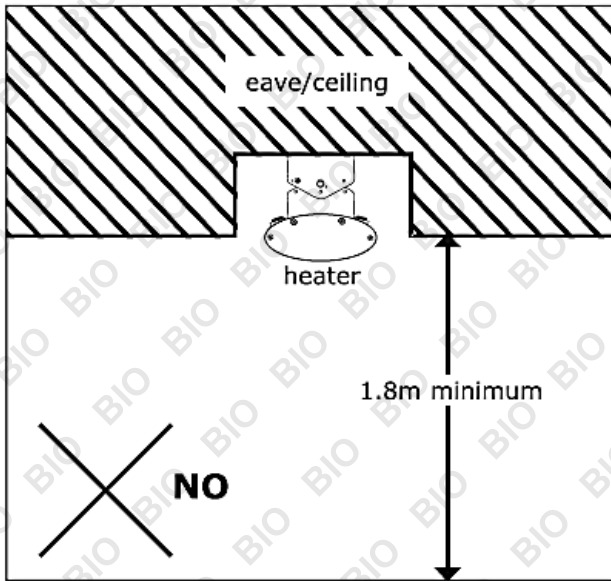

Operation

1. Plug into a 240V AC wall socket.
2. To turn ON – switch the wall socket on.
3. Turn OFF – switch the wall socket off.
4. Unplug lead from wall socket when not in use.



The heater (3200W) is a 15AMP electric heater. This requires a special 15AMP power socket to be installed by a qualified electrician before being able to use.

Maintenance



Always ensure that the wall heater has been left for one (1) hour to cool before cleaning.

1. Turn off and disconnect from mains power, allow to cool.
2. Wipe unit over with a damp, clean, soft lint-free cloth.
3. For stubborn marks, you can use a mild dish washing solution on a damp, clean, soft, lint-free cloth.



NEVER allow water or a mild dish washing solution to enter or drip onto the wall heater.

NEVER use solvents, e.g. Petrol, Toluene, Methylated Spirits etc. to clean the floor heater, as these will damage the surface finish and may cause a fire when unit is next used.

Specifications

Spectra 18

Power	1800W
Material	Anodised Aluminium
Input Voltage	240V AC
IPx4 rated	Splash Resistant
Cord Length	1.5m
Plug Standard	3 pin 15 Amp
Power Plug	Australian Standard

Spectra 24

Power	2400W
Material	Anodised Aluminium
Input Voltage	240V AC
IPx4 rated	Splash Resistant
Cord Length	1.5m
Plug Standard	3 pin 15 Amp
Power Plug	Australian Standard

Spectra 32

Power	3200W
Material	Anodised Aluminium
Input Voltage	240V AC
IPx4 rated	Splash Resistant
Cord Length	1.5m
Plug Standard	3 pin 15 Amp
Power Plug	Australian Standard

NOTE: The 3200W Bio Electric Radiant Strip Heater requires installation by a licensed electrician to a 15A circuit



Some experts believe that the incorrect or prolonged use of almost any product may cause serious injury or death. To help reduce your risk of serious injury or death, refer to the information below. For more information, see www.datastreamserver.com/safety

- Consult all documentation, packaging and product labelling before use. Note that some products feature documentation available online. It is recommended to print and retain the documentation.
- Before each use, check the product for loose/broken/damaged/missing parts, wear or leaks (if applicable). Never use a product with loose/broken/damaged/missing parts, wear or leaks.
- Products must be inspected and serviced (if applicable) by a qualified technician every 6 months. This is based on average residential use by persons of average size and strength, and on a property of average metropolitan size. Use beyond these recommendations may require more frequent inspections/servicing.
- Ensure that all users of the product have completed a suitable industry recognised training course before being allowed access to the product.
- The product has been supplied by a general merchandise retailer that may not be familiar with your specific application or description of application. Be sure to attain third-party approval from a qualified specialist for your application before use, regardless of any assurances from the retailer or its representatives.
- This product is not intended for use where fail-safe operation is required. As with any product (for example, automobile, computer, toaster), there is the possibility of technical issues that may require the repair or replacement of parts, or the product itself. If the possibility of such failure and the associated time it may take to rectify could in any way inconvenience the user, business or employee, or financially affect the user, business or employee, then the product is not suitable for your requirements. This product is not intended for use where incorrect operation or a failure of any kind, including but not limited to, a condition requiring product return, replacement, parts replacement or service by a technician may cause financial loss, loss of employee time or an inconvenience requiring compensation.
- If this product has been purchased in error when considering the information presented here, contact the retailer directly for details of their returns policy, if required.



©2018 Bio. All rights reserved. No part of this document, including descriptive content, concepts, ideas, diagrams or images may be reproduced or transmitted in any form or by any means, electronic or mechanical, including photocopying, scanning or recording, or any information storage and retrieval system, without express permission or consent from the publisher.