



# Mi Robot Vacuum Cleaner

## User Manual

[Revision 2.0 February 2018]

---

READ THIS MANUAL CAREFULLY BEFORE USE – FAILURE TO DO SO MAY RESULT IN INJURY, PROPERTY DAMAGE AND MAY VOID WARRANTY. • KEEP THIS MANUAL FOR FUTURE REFERENCE. • Products covered by this manual may vary in appearance, assembly, inclusions, specifications, description and packaging.

---

# Table of Contents

**Introduction**

---

**Overview**

---

**Usage**

---

**Daily Care**

---

**Troubleshooting**

---

**Information about Safety**

---

**Connecting to Wi-Fi and the Smartphone App**

---

**Changing the Vacuum Cleaner Language to English**



User Manual of «MiJia» vacuum cleaner  
Before using the product, please carefully read this manual and save it properly

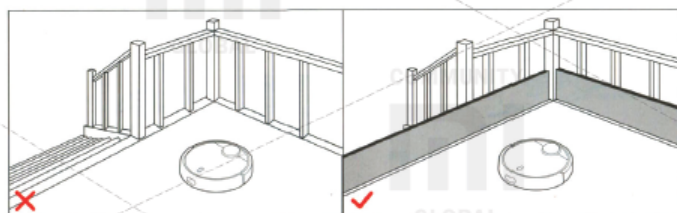
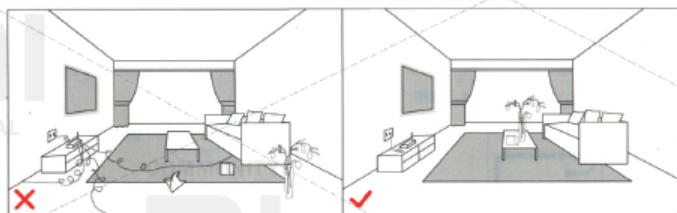

#### Caution

Before you start cleaning, make sure, that there were no wires and foreign objects on the floor, which are easily overturned, broken or valuable items that may be damaged, or that may be confusing the unit, because of which sticking, collision or whatever may happen way prejudiced person and property.

If the device is used in a space, where there is a height difference, take care of a reliable physical protection - anti-fall device screen, to prevent damage to people and property.

Attention! During a first cleaning, please follow the device personally, and help him in emerging issues - after issues such cleaning is hassle-free. If there are some areas, that do not require cleaning, and the unit can get stuck in them, get a virtual barrier that will deter the unit from entering the above-mentioned areas.

#### 1. Connect power cable. Excess of cable is pulled into the housing trough.

Attention! Power cord, hanging down on the floor, can be entangled by the cleaner, or removed from the power outlet, which will cause power interruption.

#### 2. On a flat surface set a charging base and connect it to power supply.

Note: Make sure that both sides of a charging base have at least 0.5 m, and front surface has at least 1.0 m of free space.

#### 3. Turning and charging the device.

Press and hold the O button, wait for the ring lamp lights up and press the device to a charging base.

**Colour of** ring indicator lamp shows an amount of electric charge:

White - 50%;  
Yellow - 50% -20%;  
Red - less than 20%.

Attention! At too low battery level you can not turn on the device, in this case, please press the device to a charging base.

#### QR code

Fing «Mi Smart Home» App on the manufacturer's page or scan two-dimensional code and download the mobile app, open the lid of the device and search for Wi-Fi status indicator lamp. Follow the instructions in the application.



#### Wi-Fi status indicator

Slow flashing: Waiting for connection;  
Fast flashing: There is a connection;  
Continuous combustion: Wi-Fi connection.

Attention! When phone is not connected to a robot cleaner, see «Operating Instructions» - «Reset Wi-Fi».

#### 5. Start Cleaning.

When the round charging indicator finishes blinking white light in the respiratory rate and glows white steady light, it indicates that the device is charged. In this case, briefly press the O button or start the device with a mobile phone.

**Thank you for choosing «MiJia» robot cleaner.**

«MiJia» robot cleaner - the clever device, which plans a route of cleaning, it is equipped with highly sensitive optical laser and ultrasonic sensors, measuring a distance, and in real-time can build a plan of a room; using space sensors, scanning cleaning route, so cleaning is performed a complete, comprehensive, high-performance. Cleaning can be carried out in difficult spaces, after cleaning the unit automatically returns to charging, while working, he does not require human attention. You can also remotely control the device, using mobile application, you can see cleaning scheme and its condition, set cleaning schedule in this one. Science and technology are changing lives. Starting today, you and your family free from a hassle of cleaning the floor. Enjoy the pleasures of life, use the device with pleasure!

Main device

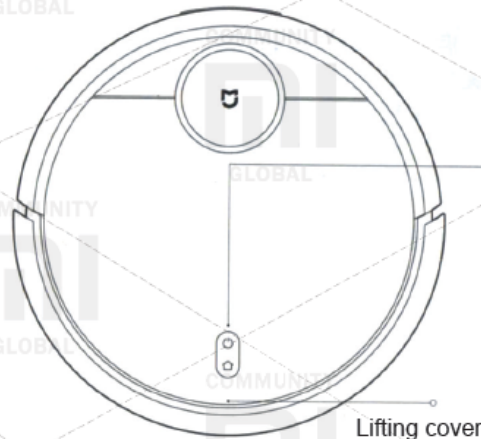

Charging base



Brush cleaning device



Power cable

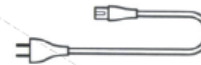

Cleaning / On/Off  
Start cleaning by short pressing.  
Long pressing - On/Off the device.

Ring indicator lamp;  
White color: battery level more than 50%;  
Yellow: 50% - 20%;  
Red: battery level less than 20%;  
Blinking in the respiratory rate: recharge or run;  
Fast flashing red: alarm condition.

Return for charging / partial cleaning.  
Make a short press the button to return to the charging.  
Long press activates a partial cleanup.

Attention! If during cleaning, recharging or partial cleaning, press any button, all the action of the vacuum cleaner temporarily stops.

## Overview

Main device

Dust collector

Charging base

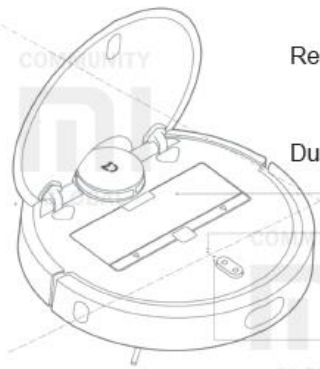

Reset button

Dust collector cover

Indicator light Wi-Fi  
 Slow flashing: Standby connection;  
 Fast flashing: there is a connection;  
 Continuous combustion: Wi-Fi connection has occurred.

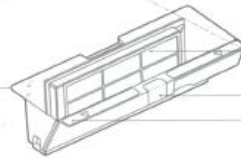

Filter grid

Dust collector clamp

Identification zone

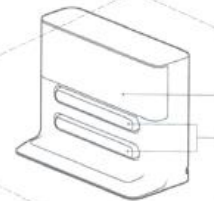

Charging contacts

Clamp

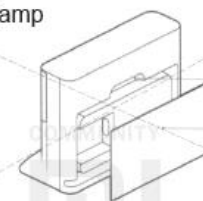

Back cover

Cable housing

Power cable socket

Cable outlet

Attention! The cable can be removed, both right and left.

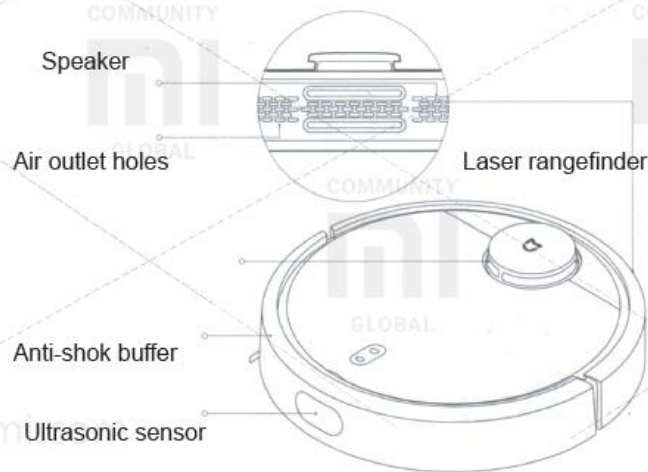
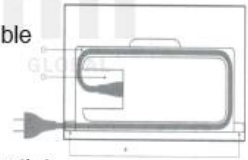

Speaker

Air outlet holes

Anti-shok buffer

Ultrasonic sensor



Laser rangefinder

Sensor of hovering

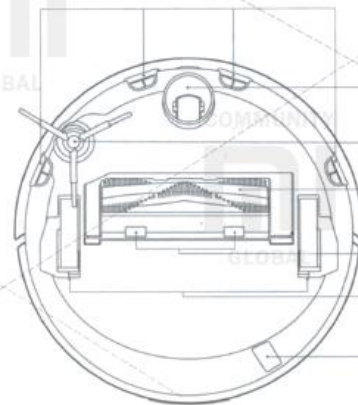

Wheel

Side brush

Main brush

Main brush lid clamp

Main wheels

USB port for settings

## Usage



**1. Connect power cable.** Excess of cable is pulled into the housing trough.

Attention! Power cord, hanging down on the floor, can be entangled by the cleaner, or removed from the power outlet, which will cause power interruption.

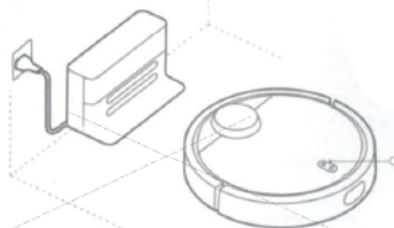

**Colour of ring indicator lamp** shows an amount of electric charge:

White - 50%;  
Yellow - 50% -20%;  
Red - less than 20%.

Attention! At too low battery level you can not turn on the device, in this case, please press the device to a charging base.



**2. On a flat surface** set a charging base and connect it to power supply.

Note: Make sure that both sides of a charging base have at least 0.5 m, and front surface has at least 1.0 m of free space.

**3. Turning and charging the device.**

Press and hold the O button, wait for the ring lamp lights up and press the device to a charging base.



**4. QR code**

Find «Mi Smart Home» App on the manufacturer's page or scan two-dimensional code and download the mobile app, open the lid of the device and search for Wi-Fi status indicator lamp. Follow the instructions in the application.

**Wi-Fi status indicator**

Slow flashing: Waiting for connection;  
Fast flashing: There is a connection;  
Continuous combustion: Wi-Fi connection.

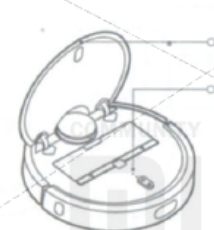

Top lid

Wi-Fi status indicator

**5. Start Cleaning.**

When the round charging indicator finishes blinking white light in the respiratory rate and glows white steady light, it indicates that the device is charged. In this case, briefly press the O button or start the device with a mobile phone.

## Usage

### On/Off

Long press O button and the device is turned on, indicating ring lamp lights up and the cleaner listens for commands. When the appliance is in standby (quiescent), long press O button to switch off, cleaning is finished.

Attention! it is impossible to turn off the device during charging.

### Cleaning.

After short pressing O button cleaning starts (cleaning algorithm, see the diagram on the right). Pressing any button during cleaning comes a pause mode.

### Caution!

At too low a charge is impossible to start cleaning up, please charge the device and start again.

When, during the cleaning, a battery level falls below a critical line, the unit automatically returns to base to recharge, after the recharge to an acceptable level, it automatically returns to a place, where cleaning was interrupted, and continues it.

Before cleaning, please make sure, that no wire on the floor (including power cable from a charging station), to prevent them tangling the device and pulling them out of the network, damage wires and objects.

If cleaning is finished in less than 10 minutes, it is performed again by default.

### Charging.

Auto: After cleaning, the unit automatically returns to base to recharge.

Manual: During pause, quickly press «Home» button, then the unit returns to base to recharge and ring indicator lamp starts flashing slowly.

### Note!

If the device is unable to find a charging base, help him manually.

### Cleaning algorithm

After starting a cleaning, the device performs its intellectual scheme of scanning, along the walls, dividing the space into zones, building zones of cleaning route as Latin letter Z.

When the cleaner have finished cleaning in one area, it moves to the next with no gaps. When the entire cleaning is finished, the device automatically returns to base to recharge.

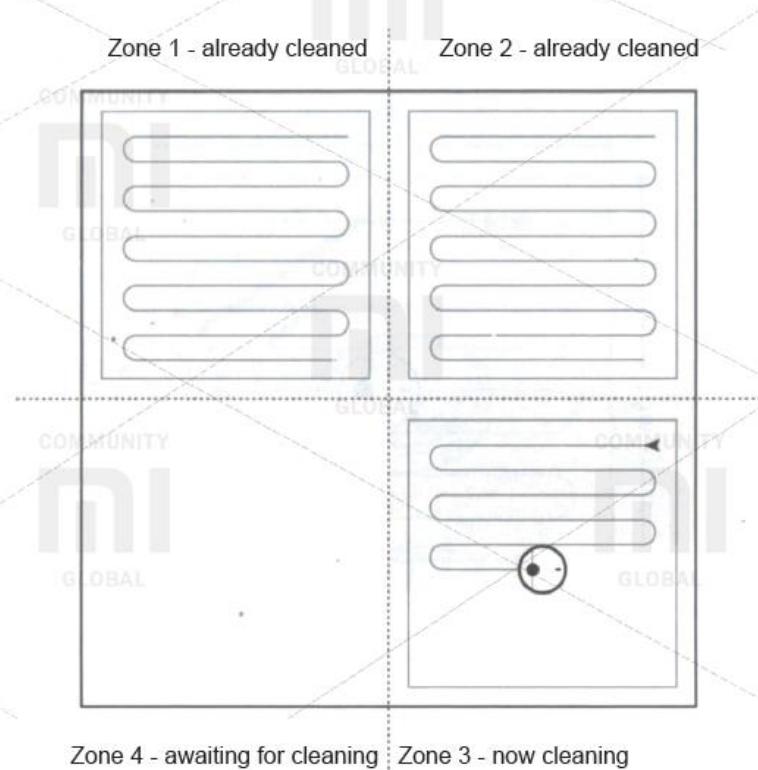

### Partial cleaning

While the device is in standby or pause, long press «Home» button, a partial cleaning automatically begins; its algorithm is cleaning zone 1,5 m x 1,5 m around the device, after the vacuum cleaner automatically returns to the starting point of partial harvesting and goes to stop mode.

Attention! If during a partial turn pause mode, cleaning will be completed.

### Pause

During a movement of device, press any button.

When you click O button, cleaning continues. When you press «Home» button, unit returns to base to recharge and cleaning will be completed.

Note: If, during a pause, you press the device to a charging base, cleaning will be completed.

### State of accident

When, during the motion of the device, fault occurs, ring light indicator starts rapidly flashing red, accompanied by a voice indication. Ways to solve emergency problems, see. «Solving problems upon detection of faults.»

### Note!

If an alarm condition occurs, and the device not taken more than 10 seconds, it automatically goes into sleep mode.

If in event of an emergency condition, press the device to charging base, the cleaning will be completed.

### Sleep mode

If the unit does not operate for more than 10 seconds, it automatically goes into sleep mode. A ring light indicator flashes red once per second.

If, during sleep, press any button, the device can be awakened.

### Note!

During charging on a basis, the device may not enter Sleep mode.

After 12 minutes in Sleep mode, it automatically turns off.

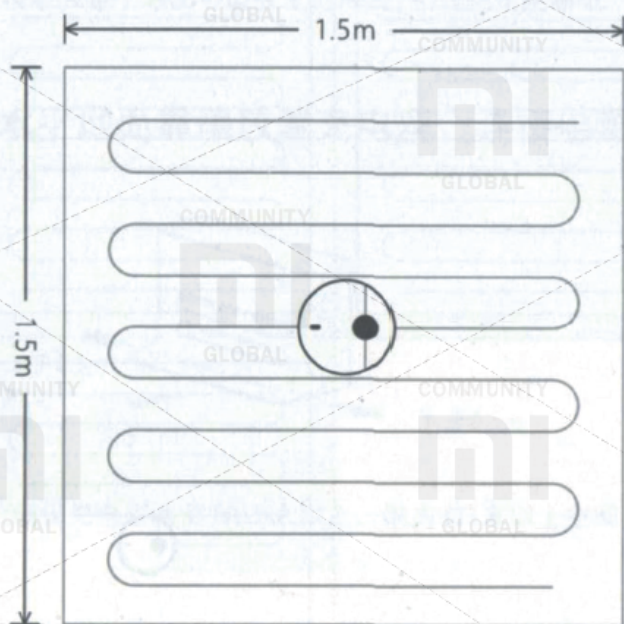



## Planning of cleaning

Using the mobile app, you can schedule cleaning for some time, and the unit will automatically start cleaning at a selected time, and after automatically return to base to recharge.

## Wi-Fi Reset

When, for hardware reasons, or if you have forgotten Wi-Fi password, etc., you can not connect and operate the device, using a mobile phone, open an upper hinged cover, and then you will see a Wi-Fi status indicator, simultaneously press and hold the buttons **O** and «Home», at this time you will hear a voice command «Reset Wi-Fi». Wait, till indicator flashes slowly again, restart was successful.

## Cleaning algorithm

With the mobile app, you can choose a quiet, normal and energetic cleaning mode. By default, the standard mode.

## DND mode

In «Do Not Disturb» mode the instrument can not continue to clean and speech means informs about it. Frequency of ring indicator flashing reduced. «Do Not Disturb» mode configured to 22.00 to 08.00 by default. With the mobile application mode «Do not disturb» You can enable or reprogram his time ...

## Virtual barrier

This is a non-standard addition, can be purchased at [www.mi.com](http://www.mi.com) Virtual barrier can be used to limit the location of undesirable areas for the device, for example, dangerous changes in levels, steps, places where it is possible jamming device.

Attention! Very carefully and firmly attach barriers, that they do not come unstuck, otherwise their application will be ineffective.

## Virtual barrier

Attention! Place virtual horizontal barriers on the way of the device.

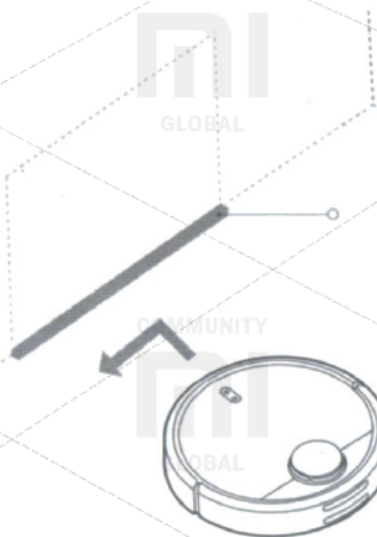
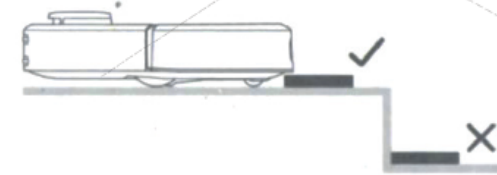

## Charging base

Base for recharging should be placed on a flat surface, leaning to wall, providing each side of not less than 0.5 m, and in front of at least 1.0 m of free space, and attached to a power outlet. To ensure satisfactory reception of Wi-Fi mobile phone, its position in the area of good signal.

Attention! Do not place the recharging base in the areas of direct sunlight or in places, where access to it is difficult, and there can be problems with the device for return to the recharging base.

## Daily care

### Main brush. Weekly cleaning recommended

1. Click on a tab at the bottom of the device and remove a main brush;
2. Pull a main brush and clean bearings of the main brush;
3. Clean hair, tangled on the main brush, using a tool to clean the main brush that is included;
4. Replace the main brush and secure it with the cover latch.

### Note!

It recommended for cleaning effectiveness every 6-12 months change the main brush

0.5m

1m

0.5m

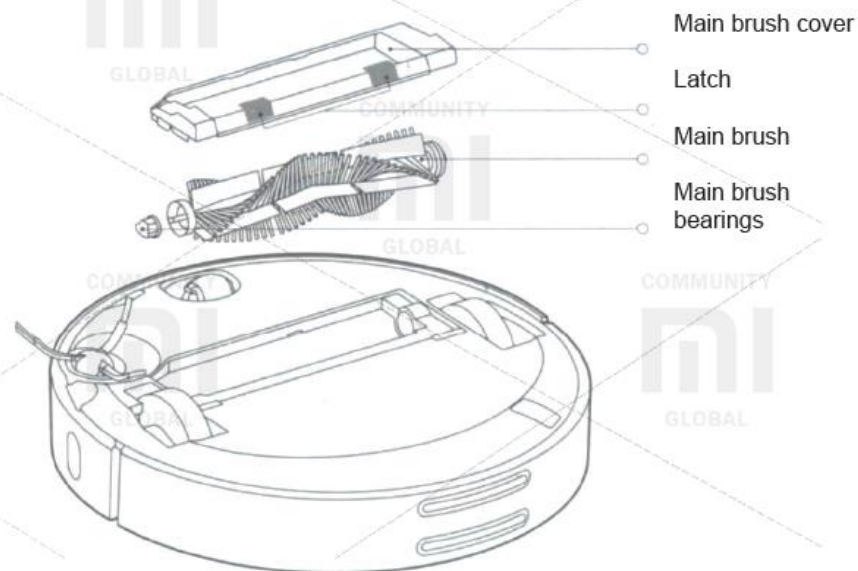

## Daily care

A method of cleaning the main brush with supplied tool.

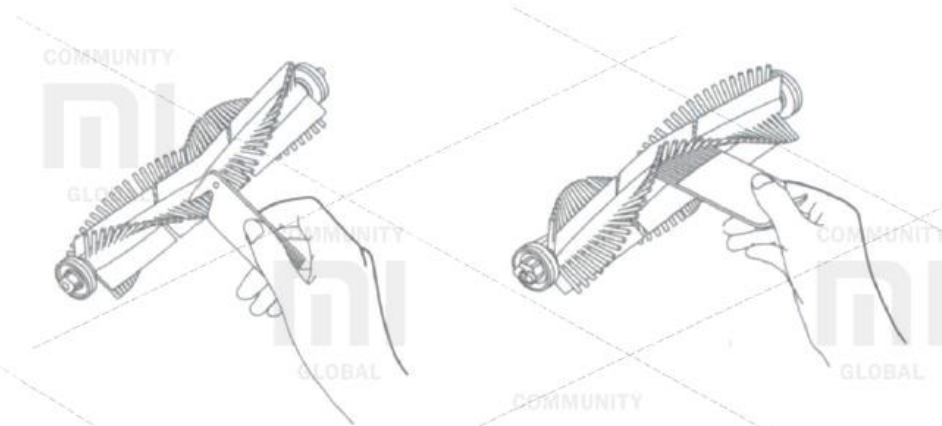

2. Open the front cover of the dust container

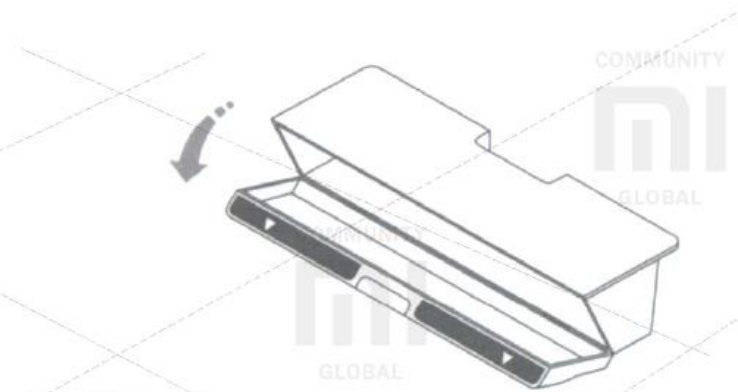

### Dust collector and filter grid

It is recommended to clean weekly.

1. Lift a top cover of the device, press a latch and pull a dust collector.



3. Empty trash from the dust collector

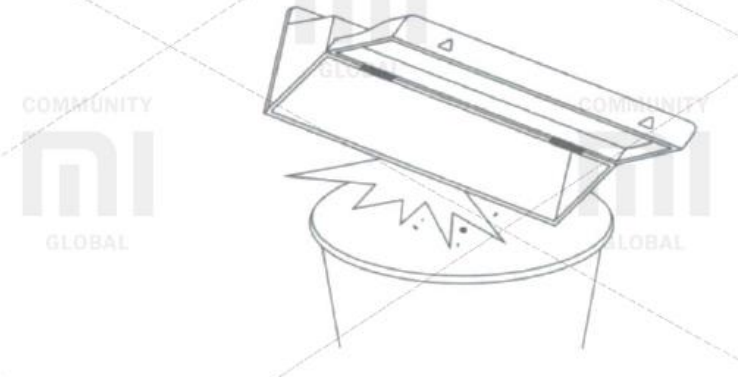

Attention! To avoid clogging the filter mesh, please knock on the dust collector, emptying trash.

Filter grid can not be washed with water, otherwise it becomes clogged with dust, and it will affect a cleaning efficiency.

Attention! It is recommended to be changed filter grid every 3 months to ensure cleaning efficiency.

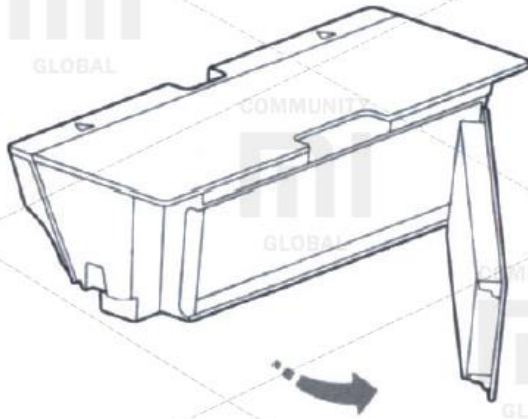

Remove and change a filter grid, as illustrated

### Battery

The device used a powerful high-performance lithium-ion battery pack; during daily use of the device, please watch a battery status.

Attention! If the device is not used for a long time, during storage of the device at least once in 3 months to charge a battery to prevent abnormal discharge of batteries.

### The side brush should be cleaned monthly

1. Turn off the device and remove a side brush mounting screws;
2. Pull out and clean a side brush;
3. Place a side brush back and tighten the screws.

Attention! It is recommended every 3 - 6 months change a side brush to ensure cleaning efficiency.

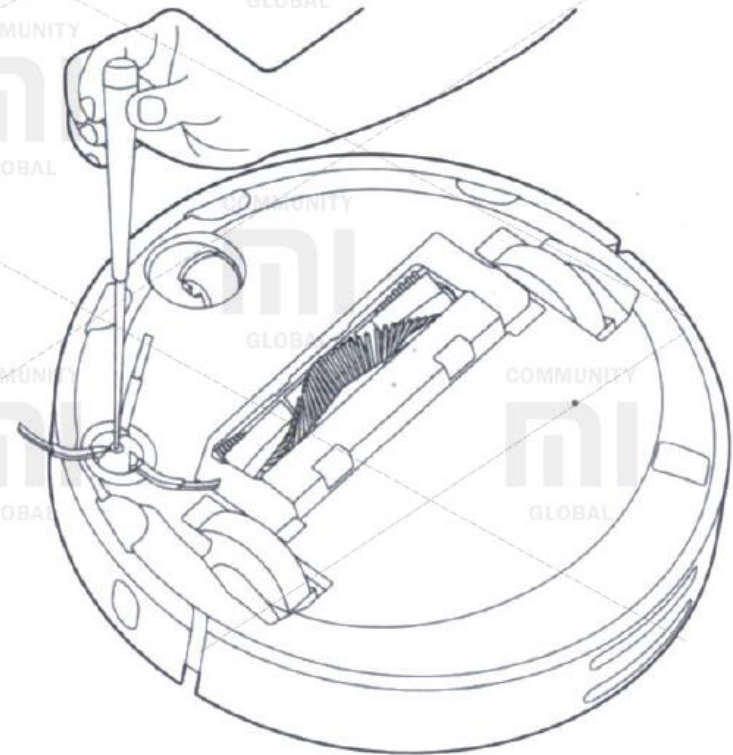

**Turning wheel; «360 degrees»**  
recommended to clean daily

1. Turn off the device and remove turning wheel;
2. Clean a wheel and its bearings from hair and sticky substances;
3. Fit a wheel back.

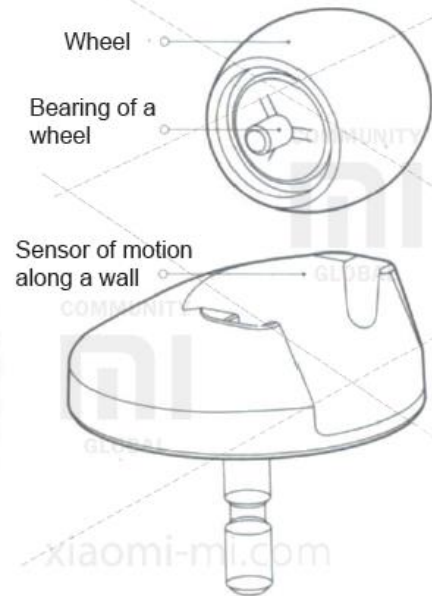

**Sensors of the device**  
recommended to clean monthly

Use a clean cloth to clean all sensors of the cleaner, including:

1. Four sensor hovering over a bottom rung of the device;
2. The motion sensor along a wall at the right of the device;
3. Charging contacts at the back of the device.

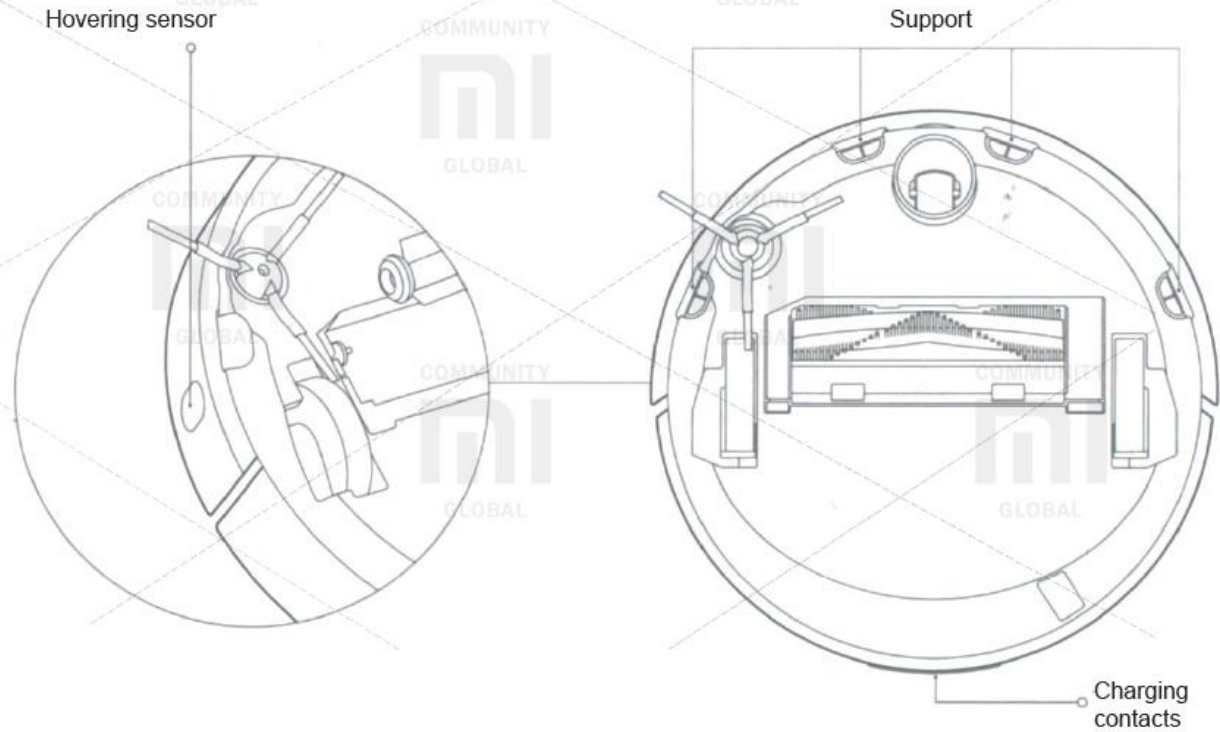

### Charging base

recommended to clean monthly  
Use a clean cloth to clean contacts.

### Software update

Use an mobile app to update the device's software, before update, make sure that charge is at least 20%.  
When you update a software, ring indicator light quickly flashes white.

### System reset

If there is no response on pressing buttons or inability to turn off the device, please try to reboot the system by pressing a system reset button (see. Section 2), and the unit will automatically start again.  
Attention! Rebooting the system will destroy properties of scheduled cleanings and cleaning modes and also to reboot the Wi-Fi connection.

### Reset to factory settings

If, after reboot, normal operation of the device is not restored, press and hold «Home» button and simultaneously press once a system reboot button, you will hear a voice message «Return to initial factory settings» and system will return to factory settings.

Main parameters	
Dimensions	345X345X96 mm
Battery	14,4 v/5200 mAh Lithium
Weight	About 3,8 kg
Wireless connection	Wi-Fi, fast
Rated voltage	14,4 V
Rated power	55 W
Charging base	
Dimensions	230X109X129 mm
Rated power	55 W
Rated voltage	100 – 240 V
Output rated voltage	20 V., 2,2 A
Rated frequency	50 / 60 Hz

### The name and contents of harmful substances

Parts	Harmful substance					
	Pb	Hg	Cd	6-valent Cr	Polybrominated biphenyls	Polybrominated diphenyl ethers
Circuit board	x	o	o	o	o	o
Metallic parts	o	o	o	o	o	o
Housing	o	o	o	o	o	o
Battery elements	o	o	o	o	o	o
Other parts	o	o	o	o	o	o

This specification is designed on the basis of requirements, established by SJ / T 11364 regulations.

O shows, that the content of this harmful substance in the said portion below the permissible GB / T 26572 standard level.

X shows, that the content of this harmful substance in the said part at least in one city over the allowable GB / T 26572 level 5 standard.

## Troubleshooting

In the event of emergency situations, a ring indicator light flashes red rapidly and you will hear a voice message. In this case, please review contents of the table and fix a problem.

System reset  
should solve some  
problems

Fault indication	Method of resolving
Error 1: Please check whether a surface of laser distance sensors is not blocked.	If laser distance sensors is covered by foreign objects, you need to remove it and clean sensors, if then the device does not start, move it to a new place and try to run.
Error 2: Clean and lightly stir collision sensors.	Collision sensors are stuck, please move them slightly and remove foreign objects, if there are no foreign objects, move the device to a new location and try to run.
Error 3: Move the device to another location and start.	Wheels hung over the void. Move the device to a new location and run.
Error 4: Clean hovering sensors, move the device to a new location and run.	The device has been in place, where there is a height difference. Move the device to a new location and run; if sensors are hovering over a step very clogged, they can stop working; wipe them.
Error 5: Clean a fishing line and bearings of the main brush.	Foreign objects reeled on a main brush. Remove them and clean a bearings and a fishing line of reeled the main brush.
Error 6: Remove and clean the side brush.	Foreign objects reeled on a side brush, remove a side brush and clean it.
Error 7: Check if main wheels stuck. Move the device to a new location and run.	Foreign objects reeled on main wheels. Clean them, move the device to a new location and run.
Error 8: Clean an area around the device from obstacles.	The device can be stuck. Clean an area around the device from obstacles. Move the device to a new location and run.
Error 9: Replace a dust collector and filter grid.	Replace the dust collector and filter grid, check whether they are in their places; If yes, but the problem persists, check and adjust the filter grid.
Error 10: Clean or change a filter grid.	The filter grid can be clogged, clean it, if you cannot check - change it.
Error 11: There may be strong magnetic fields, move the device from a virtual barrier.	When launching, the device was at a virtual barrier. Move the device to a new location and run.

Indication of fault	Method of resolving
Error 12: Battery level is too low, recharge the device.	The charge is insufficient, please recharge the device and enjoy more.
Error 13: Charging fault, check contacts on a charging base.	Clean contacts on a charging base and on the device with a soft cloth.
Error 14: Battery fault.	Batteries overheated or too cold, soak the cleaner in normal temperature and use it again.
Error 15: Wipe moving along wall sensors.	Orientation along a wall sensors covered with dust, wipe them.
Error 16: Place the device on a flat surface and start again.	When launching, the device was on an incline. Place the device on a flat surface and start again.
Error 17: Side brushes fault: reset the system.	Side brushes does not work as it should. Reboot the system.
Error 18: Suction fan fault, check it and try to reboot the system.	The suction fan is not working as it should. Check it out and try to reboot the system.
Error 19: There is no current on recharging base. Check connection to a power supply.	Charging base power cable can be turned out of a socket, check, plug it in and start the cleaner again.
Internal error, try to reboot the system	If the device does not work, try restarting the system.

## Information about safety

Information about dangers of laser light: Laser distance measurement sensor on this unit complies with IEC 60825-1: 2014 Product type 1, and causes no harmful laser radiation.

Executive Standard: GB 4706.1-2005, GB 4706.7-2005, GB 4343.1-2009, GB17625.1-2012, Q / BJSTS0001-2016, Q / BJSTS0002-2016

The list of possible malfunctions of the robot cleaner «MiJia»

A list of specific malfunctions of the robot cleaner «Mijia»	
Name	Malfunction
Main unit	Low efficiency, then described in user's instructions.
	The device no turns on.
	A main brush, side brush, fan, wheels not work.
Charging base	No current on the main unit
Power cable	No power on charging base

### Manufacturer:

Beijing Stone Century Science Technology Co., Ltd. (Xiaomi Ecological chain enterprise)  
Product SKU: SDJQR01RR  
Address: Beijing, Haidian District, Heiquan Road, 8, Block C, 6th floor, office 6016,6017,6018  
Executive Standard: Q / BJSTS0001-2016, Q / BJSTS0002-2016

Direction: Xiaomi Communication Technology Co. Ltd.  
If you have questions regarding the list of organizations authorized to carry out maintenance Xiaomi, please read it online [www.mi.com/service](http://www.mi.com/service) or call Xiaomi service.



## Connecting to Wi-Fi and the Smartphone App

The vacuum cleaner features some advanced options, including notification etc, through a smartphone "app". For example, remotely start and stop the vacuum cleaner, inform you when it has finished a job, requires emptying, show its cleaning path etc. Connection between your smartphone and the vacuum cleaner is through a Wi-Fi service. The vacuum cleaner must be able to connect to a Wi-Fi service to use the smartphone app. Note that it is not mandatory to use the smartphone app. Install and set-up the smartphone app and vacuum cleaner Wi-Fi connection as follows:

1. On your smartphone, download the Mi Home app from Google Play or the App Store, alternatively use the following QR code (your phone requires a "QR reader" application to do this) and download the application.

Scan either one of these QR codes, depending on your operating system:

**iOS**



**Android**



The Mi Home app logo looks like this:

2. Create an account, then sign in to the application using your new account. Once done, you will come to the **Mi Home** application main page which will display some information; for example, temperature of the location you are in.

## Setting the Server

To enable you to connect your vacuum to the app, you need to select a Server, different Servers have different Xiaomi products linked to them. You will need to connect to the Singapore Server, here is how:

1. From the main screen of the app, tap **Profile**.

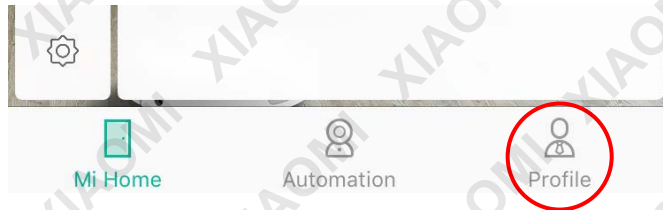

2. Now select **Settings**.

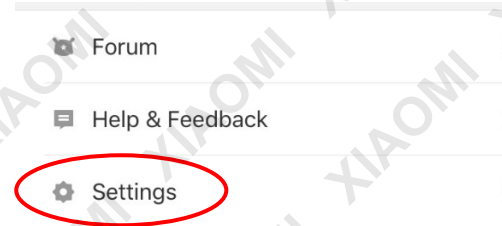

3. Now **Locale**.

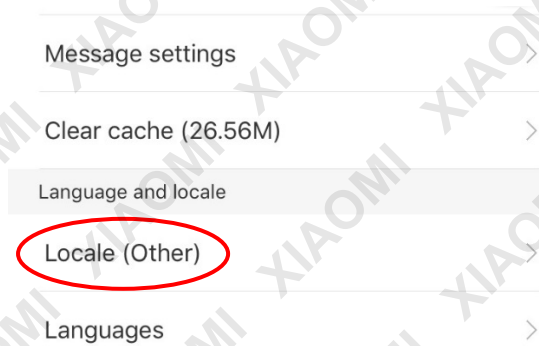

4. From the list of Servers, select **Singapore**.

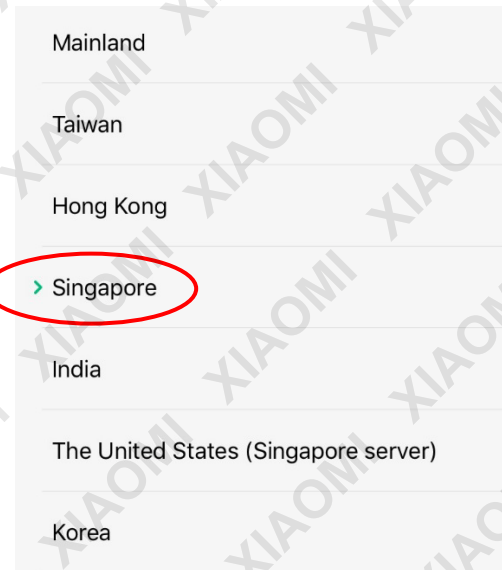

5. Return to the **Mi Home** main page.

## Adding the Robot Vacuum

1. From the **Mi Home** application main page, then tap + in the top-right corner to add a device.



2. Scroll through the list of products and select the Vacuum.

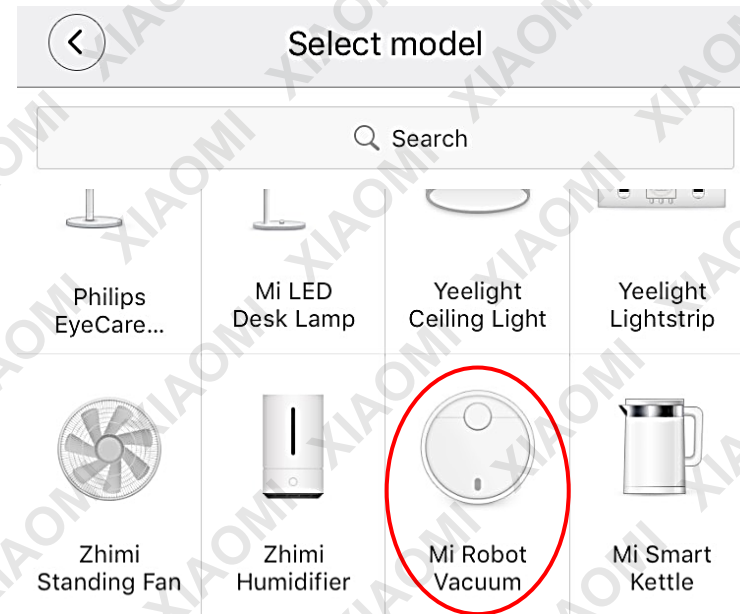

3. Lift the vacuum cleaner lid - the Wi-Fi indicator should be flashing blue.

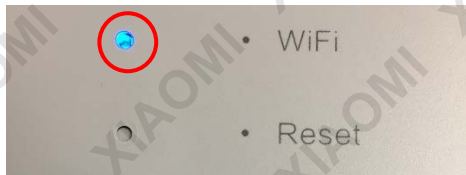

4. In **Mi Home** application, tap **Blue Light Blinking**, then tap **Next**.

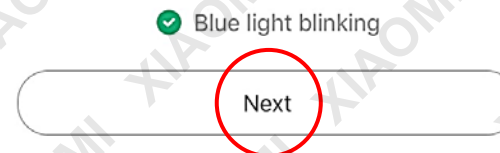

5. Select your Wi-Fi and enter your Wi-Fi password, then tap **Next**.

Cancel

Select Wi-Fi network



Myspace



Show password

7. Then select Wi-Fi.



Aeroplane Mode



Wi-Fi



Bluetooth

Myspace >

On >

6. Tap **Set Wi-Fi Now** to display available connections, then tap the vacuum cleaner Wi-Fi name to select it. The smartphone and vacuum should now be connected.

! Current Wi-Fi: Myspace

Set Wi-Fi now

8. Select the Vacuum from the list.

Wi-Fi



✓ Myspace



CHOOSE A NETWORK...

M-OFFICE



rockrobo-vacuum-v1\_miap3AB5



9. Once the Vacuum is recorded as the connected Wi-Fi, return to the **Mi Home** app.



11. Once connection is complete, follow the prompts to complete set up.

10. Note the app will run through the connection set-up.

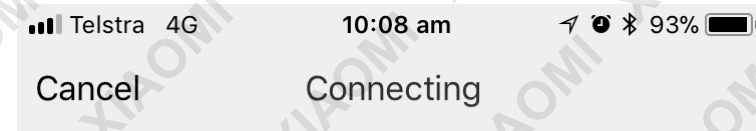

Connecting...

Keep your router, phone, and device close with each other

12. Update the Firmware if you are asked to. Please note that the Firmware update can take about 5 minutes.

Firmware update 3.3.9\_003095 available, update now?

Cancel

Update

## Sync the Vacuum Time with Your Smartphone

1. From the apps Home page, tap on the vacuum.

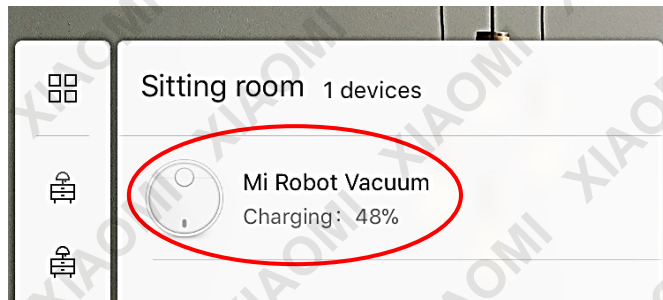

2. Agree to the Terms and Conditions.

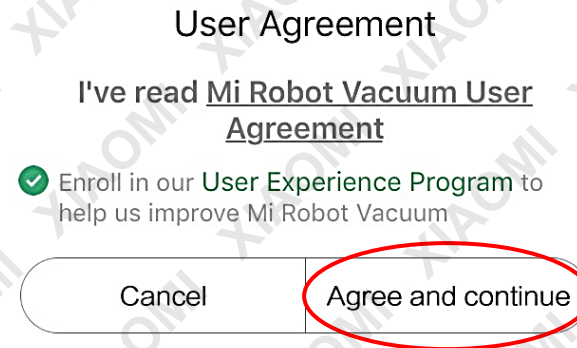

3. Tap on the 3 dots in the top right corner.



4. Tap Vacuum Settings.

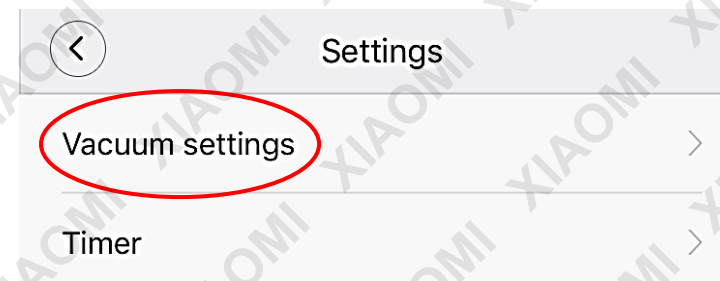

5. Tap Robot's time zone.

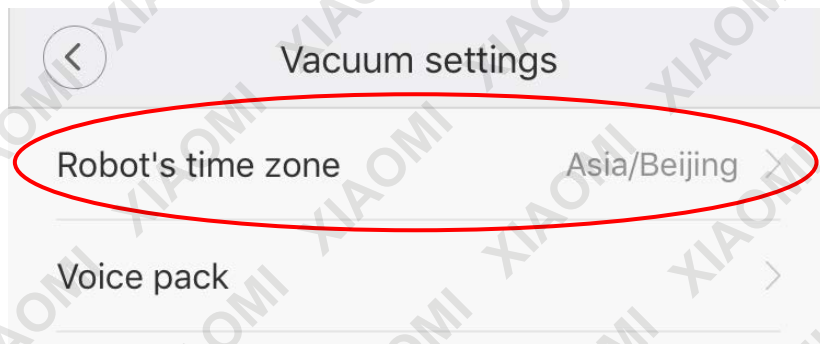

6. Now tap Sync time zones.

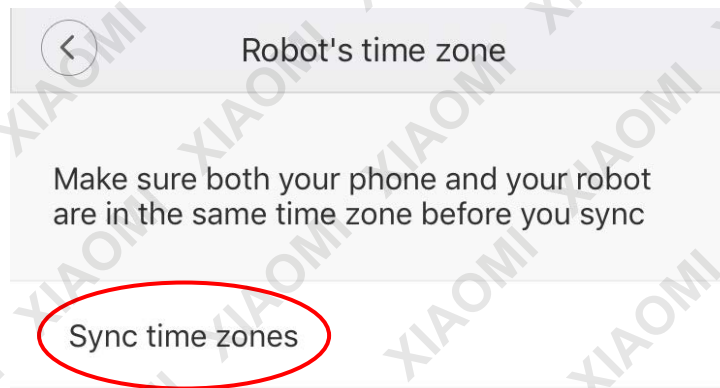

## Changing the Vacuum Cleaner Language to English

If your vacuum cleaner is not "speaking English", change it as follows:

1. Open the Mi Home app on your smartphone.

2. On the main application page, tap the name of your vacuum cleaner to open it.

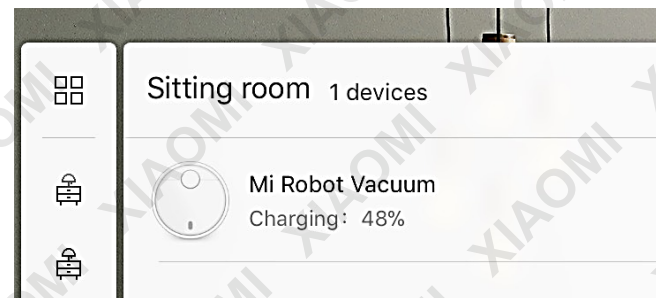

3. Tap the three dots in the top right-hand corner of the vacuum cleaner page to open its properties.



4. Tap **Vacuum Settings**.

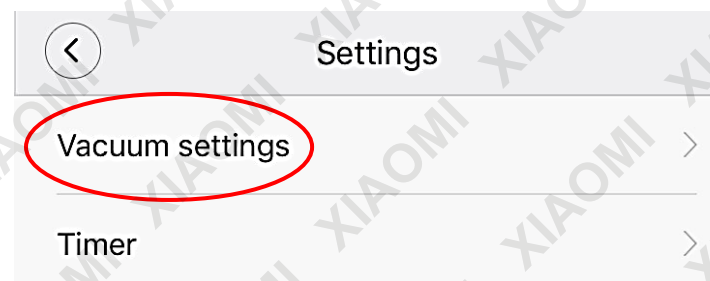

5. **Voice Pack.**

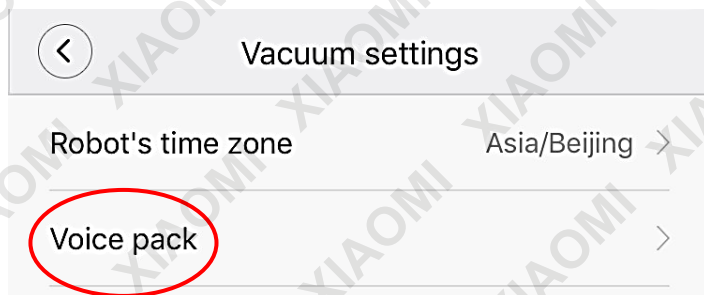

6. Scroll through the list and select **English**. The voice pack will now install.





**Some experts believe that the incorrect or prolonged use of almost any product may cause serious injury or death. To help reduce your risk of serious injury or death, refer to the information below. For more information, see [www.datastreamserver.com/safety](http://www.datastreamserver.com/safety)**

- Consult all documentation, packaging and product labelling before use. Note that some products feature documentation available online. It is recommended to print and retain the documentation.
- Before each use, check the product for loose/broken/damaged/missing parts, wear or leaks (if applicable). Never use a product with loose/broken/damaged/missing parts, wear or leaks.
- Products must be inspected and serviced (if applicable) by a qualified technician every 6 months. This is based on average residential use by persons of average size and strength, and on a property of average metropolitan size. Use beyond these recommendations may require more frequent inspections/servicing.
- Ensure that all users of the product have completed a suitable industry recognised training course before being allowed access to the product.
- If this product has been purchased in error when considering the information presented here, contact the retailer directly for details of their returns policy, if required.
- The product has been supplied by a general merchandise retailer that may not be familiar with your specific application or description of application. Be sure to attain third-party approval from a qualified specialist for your application before use, regardless of any assurances from the retailer or its representatives.
- This product is not intended for use where fail-safe operation is required. As with any product (for example, automobile, computer, toaster), there is the possibility of technical issues that may require the repair or replacement of parts, or the product itself. If the possibility of such failure and the associated time it may take to rectify could in any way inconvenience the user, business or employee, or financially affect the user, business or employee, then the product is not suitable for your requirements. This product is not intended for use where incorrect operation or a failure of any kind, including but not limited to, a condition requiring product return, replacement, parts replacement or service by a technician may cause financial loss, loss of employee time or an inconvenience requiring compensation.

